

CHEMISTRY

CHAPTER
Carbon & Its
Compounds

SAMPLE
MODULE
CLASS :10th



Online
Platform
for
NEET, JEE
& NTSE

NEET SARTHI PRE NURTURE MODULES DETAILS

| SUBJECTS | Class 6 | Class 7 | Class 8 | Class 9 | Class 10 |
|----------------------|----------|----------------------|----------|----------------------|----------------------|
| Physics | Module 1 | Module 1 | Module 1 | Module 1 | Module 1 |
| Chemistry | Module 1 | Module 1 | Module 1 | Module 1 | Module 1 |
| Biology | Module 1 | Module 1 | Module 1 | Module 1 | Module 1 |
| Maths | Module 1 | Module 1 Module 2 | Module 1 | Module 1 Module 2 | Module 1 Module 2 |
| Social Science | Module 1 | Module 1 | Module 1 | Module 1 Module 2 | Module 1 Module 2 |
| Mental Ability | Module 1 | Module 1 | Module 1 | Module 1 | Module 1 Module 2 |
| Total No. of Modules | 6 | 7 | 6 | 8 | 9 |

NEET SARTHI B2B Services

- (A) Sarthi School Integrated Programme (SSIP)
- > Tie up with school for Online or Offline Classes
 - > Classes by Kota based experienced faculties.
 - > Special emphasis on NTSE, NEET & JEE (Class 9th to 12th).
 - > Minimum student criteria - 40 per class for online and 100 per class for offline classes.
- (B) Customised study material (with your brand name)
- (C) Customised test series (According to your academic calender)
- (D) Online back up (App subscription for students and teachers)

Chemistry

PRE-NURTURE DIVISION

Sample Module English



STUDENT NAME: _____

SECTION: _____ ROLL NO: _____



CONTENTS

| Chapter No. | Topic | Page No. |
|-------------|------------------------|----------|
| 1. | Carbon & Its Compounds | 01-71 |

***“To succeed in your mission,
you must have single-minded devotion to your goal.”***



Dr. A.P.J. Abdul Kalam

Dr. A.P.J. Abdul Kalam, popularly known as the ‘Missile Man’ of India, was a source of inspiration for tens and thousands of Indians. A league apart, his life philosophy and teachings are not only admired by the older generation, but especially reminisced by young. Kalam’s prodigious rise from Rameswaram, a small but famous pilgrimage town in Tamil Nadu, led him to become one of the world’s most accomplished leaders.

***“All power is within you;
you can do anything and everything.”***



Swami Vivekananda

Swami Vivekananda ji’s original name was Narendranath. He was born on 12th January, 1863 at Kolkata (Swamiji’s Jayanti i.e. birth anniversary is celebrated as the ‘International Youth Day’). Right from childhood, two aspects of his behavior could clearly be noticed. One was his devout and compassionate nature and the other was his readiness to perform any act of courage.

Chapter-1

Carbon & Its Compounds

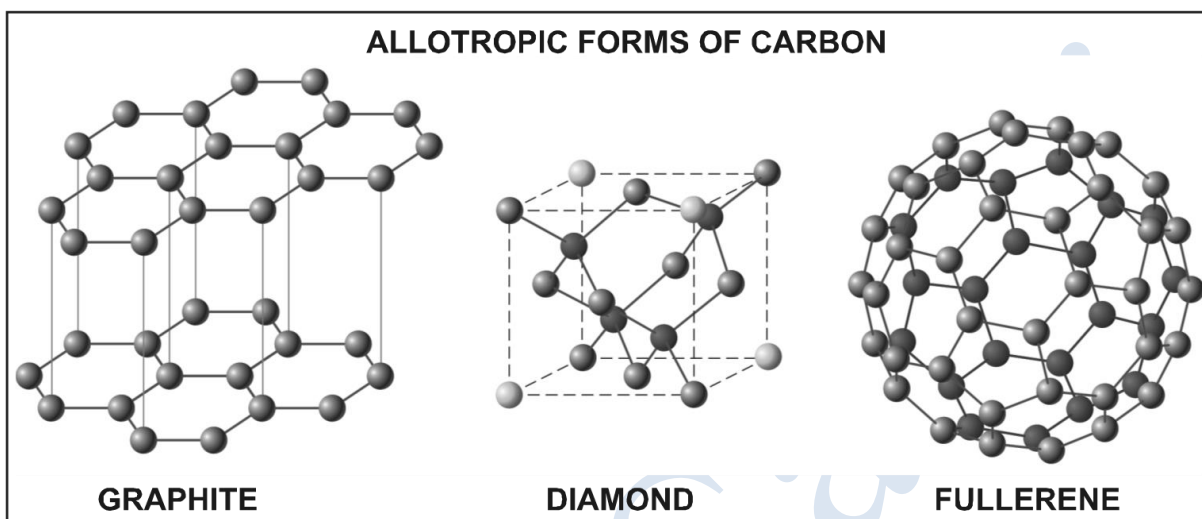

OUTLINE

- 4.1 Introduction
- 4.2 Bonding in carbon compounds
- 4.3 Allotropes of carbon
- 4.4 Versatile nature of carbon
- 4.5 Organic compounds
- 4.6 Saturated and Unsaturated hydrocarbon
- 4.7 Chains, Branches and rings
- 4.8 Functional group
- 4.9 Homologous series
- 4.10 Nomenclature of carbon compounds
 - 4.10.1 Nomenclature of compounds containing functional group
- 4.11 Isomerism
- 4.12 Chemical properties of carbon compounds
- 4.13 Some important Carbon compounds
- 4.14 Soaps and detergents

4.1 INTRODUCTION

The compounds obtained from 'Carbon' are widely used as clothes, medicines, books, food, fertilizer, fuel etc. All living structures are carbon based.

Carbon is a non-metal with symbol "C" it has an electronic configuration 2, 4. It is the most versatile element known.

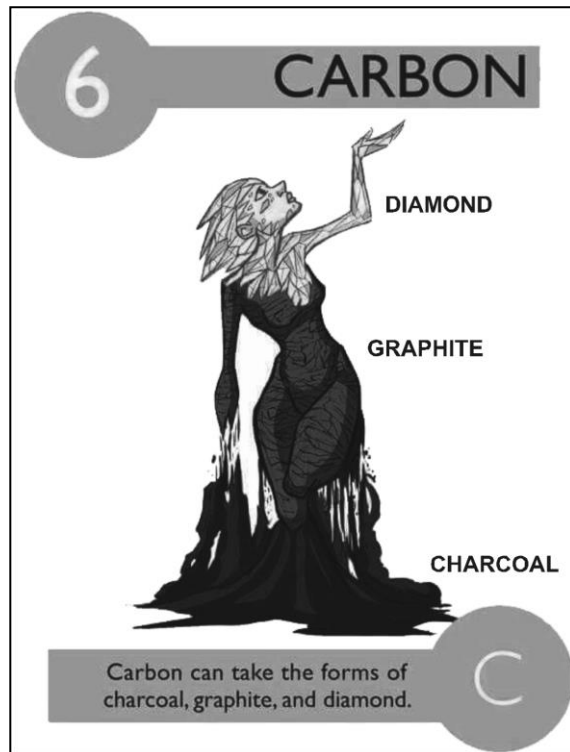

The amount of carbon present in the earth's crust and in the atmosphere is quite meagre. The earth's crust has only 0.02% carbon in the form of mineral (like carbonates, hydrogen carbonates, coal and petroleum) and the atmosphere has 0.03% of carbon dioxide. In spite of this small amount of carbon available in nature, the importance of carbon seems to be immense. Carbon forms a large number of compounds with hydrogen which are known as hydrocarbons. In addition to hydrogen, carbon compounds may also contain some other elements such as oxygen, halogen, nitrogen, phosphorus, sulphur etc.



Think Wise

- Carbon is made in giant and supergiant stars.
- Carbon is the fourth most abundant element in the universe (hydrogen, helium, and oxygen are found in higher amounts, by mass). It is the 15th most abundant element in the Earth's crust.
- Its name comes from the Latin word 'carbo,' meaning 'coal'.

4.2 BONDING IN CARBON COMPOUNDS

As neutral atom carbon has electronic configuration $2, 2, 2$. To gain inert gas configuration carbon can either donate 4 valence electrons (helium gas configuration) or gain 4 electrons (neon gas configuration), but it cannot do so for the following reasons :

- Carbon is a small atom and its valence electrons are strongly attracted by its nucleus. Therefore it cannot lose 4 electrons as it requires large amount of energy.
- Carbon cannot gain 4 electrons, because addition of 4 electrons in valence shell will result in strong electronic repulsions between 8 electrons now present in valence shell and the energy required to overcome these repulsions is very high.

To acquire inert gas configuration carbon can only share their 4 valence electrons with other atoms forming covalent bonds. A covalent bond can be defined as :

The bond formed by the mutual contribution and sharing of electrons in the participating atoms.

The compounds in which atoms are bonded by covalent bonds are known as covalent compounds.

The concept of covalent bonds was given by Langmuir and Lewis to explain bonding in non-ionic compounds. In this concept, each atom shares one electron with other atom which also contributes one electron and this mutual sharing of two electrons results in the formation of single covalent bond, and the electrons shared by both atoms form a shared pair of electrons.

Example : In hydrogen molecule both hydrogen atoms share their single electron to form single covalent bond. As shared pair is shared by both atoms, they acquire inert gas configuration of helium atom in valence shell.

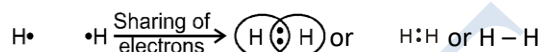

Shared pair is under influence of both nuclei and therefore electrons participating in covalent bonding are not available as free electrons. For this reason properties of covalent compounds are different from ionic compounds. Single covalent bond is represented by sign (–). Covalent bonds are only known in case of non-metals. Depending on number of electrons present in valence shell two atoms can form 1, 2 or 3 covalent bonds by sharing 1, 2 or 3 electron pairs between them.

Example : In chlorine molecule both chlorine atoms contribute one electron and thus share single electron pair to form single covalent bond. As shared pair is shared by both atoms, they acquire inert gas configuration of argon atom in valence shell.

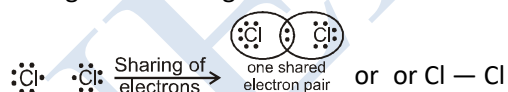

Example : In oxygen molecule both oxygen atoms contribute two electrons and thus share two electron pairs to form two covalent bonds. As shared pairs are shared by both oxygen atoms, they acquire inert gas configuration of neon atom in valence shell. Such bonds are called double bonds.

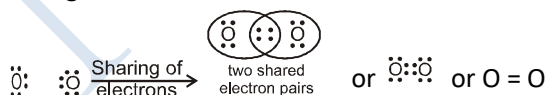

Example : In nitrogen molecule both nitrogen atoms contribute three electrons pairs to form three covalent bonds. As shared pairs are shared by both nitrogen atoms, they acquire inert gas configuration of neon atom in valence shell. Such bonds are called triple bonds.

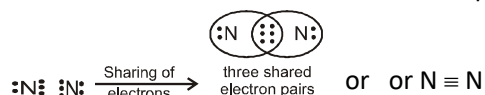

➤ **Properties of Covalent Compounds**

The important properties of covalent compounds are briefly discussed.

- (i) **Physical state** : Covalent compounds exist as single molecules which are mostly in gaseous state. For example, H₂, Cl₂, NH₃, CH₄, SO₂, etc. are gases at room temperature. However, some of them may be liquids (e.g., Br₂) and a few may exist as solids (e.g. I₂, P₄, S₈ molecules).
- (ii) **Melting and boiling points** : Since no ions are present in the covalent molecules, the attractive forces in them are weak. Therefore, these compounds have usually low melting and boiling points.

| Compound | Melting point (K) | Boiling point (K) |
|----------------|-------------------|-------------------|
| Methane | 90 | 111 |
| Methyl alcohol | 176 | 337 |
| Ethyl alcohol | 156 | 351 |
| Acetic acid | 290 | 391 |

(iii) **Electrical conductivity** : The covalent compounds are generally poor conductors of electricity because the current is carried by the movement of ions. However, some of them become good conductors when dissolved in water. For example, hydrogen chloride gas i.e., HCl_(g) is a poor conductor of electricity. But in water, it changes into hydrochloric acid, i.e., HCl_(aq). Since the acid can dissociate in solution to form H⁺_(aq) and Cl⁻_(aq) ions, it becomes a good conductor of electricity.

(iv) **Nature of reactions** : Covalent compounds generally react in molecular form. For example,

$$\text{H}_{2(g)} + \text{Cl}_{2(g)} \rightarrow 2\text{HCl}_{(g)}$$

(v) **Solubility** : We know that ionic compounds are usually water soluble. However, the covalent compounds are normally not soluble in water. They dissolve in covalent solvents like carbon tetrachloride (CCl₄), benzene (C₆H₆), acetone (CH₃COCH₃), etc.

Comparison of Properties of Ionic and Covalent Compounds

| | Covalent compounds | Ionic compounds |
|---|---|--|
| 1 | They consist of true molecules. | They do not have true molecules, but are aggregates of +ve and -ve ions. |
| 2 | They are usually gaseous or liquids or soft solids. | They are usually crystalline solids. |
| 3 | They have low melting and boiling points. | They have usually high melting and boiling points. |
| 4 | They are usually soluble in organic solvents. | They are usually insoluble in organic solvents. |
| 5 | They are usually insoluble in water. | They are usually soluble in water. |
| 6 | They are bad conductors of electricity in aqueous solution or in molten form. | Their aqueous solutions are good conductors of electricity. They also conduct electricity in molten state. |

➤ **Formation of some covalent compounds**

Lets discuss formation of some covalent compounds by Lewis dot structure/Electron dot structure.

1. Formation of hydrogen (H₂)

Atomic number of hydrogen is 1. Hence it has one electron in its K-shell and thus require one more electron to complete the K-shell and attain electronic configuration of nearest noble gas is i.e. He.

Hydrogen

| | | |
|---------------|----|--------------------------------|
| Atomic number | -1 | } Incomplete duplet (unstable) |
| Shell | -K | |
| Electron | -1 | |

Helium

| | | |
|---------------|----|----------------------------|
| Atomic number | 2 | } Complete duplet (stable) |
| Shell | -K | |
| Electron | -2 | |

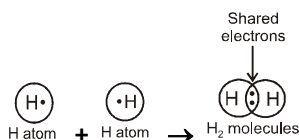

So, two hydrogen atoms share one electron each to form a molecule of hydrogen, H₂. By doing so, each hydrogen atom attains the stable electronic configuration of the nearest noble gas, helium. The formation of diatomic molecule of H₂ can be depicted by using dots or crosses to represent the valence electrons involved in sharing. Such structure of molecules are called electron dot structures or Lewis dot structures.

2. Formation of Cl₂ Molecule

The atomic number of chlorine is 17, thus there are 17 electrons in an atom of chlorine.

Electronic configuration of Cl atom –

| | | |
|-----------|-------|--------------------|
| Shells | K L M | } Incomplete octet |
| Electrons | 2 8 7 | |

Electronic configuration of Ar atom –

| | | |
|-----------|-------|------------------|
| Shells | K L M | } Complete octet |
| Electrons | 2 8 8 | |

Chlorine atom needs one electron more to complete its octet –

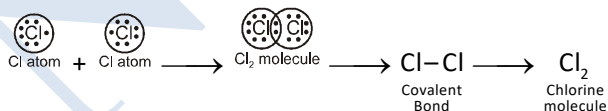

3. Formation of oxygen (O₂)

The atomic number of O atom is 8. There are 6 electrons in the valence shell of oxygen atoms, it needs 2 more electrons to attain the nearest stable inert gas [Neon (2, 8)] configuration.

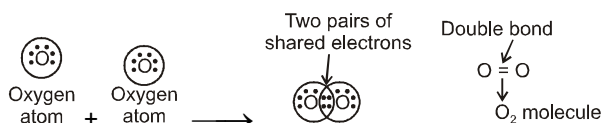

4. Formation of nitrogen molecule (N₂)

The atomic number of nitrogen is 7 and its electronic configuration is K(2), L(5). It needs 3 electrons more to complete its octet like noble gas neon (2, 8).

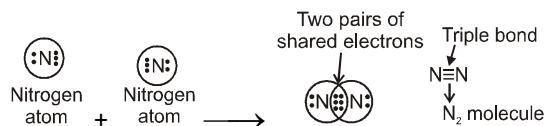

5. Formation of ammonia molecule (NH₃)

The atomic number of N is 7. Its electronic configuration is 2, 5. There are 5 electrons in its valence shell. It needs 3 electrons more to complete its octet like noble gas, neon (2, 8). Hydrogen has one electron in its valence shell and there are total 3 hydrogen atoms. All 3 hydrogen atoms will share its electron with nitrogen.

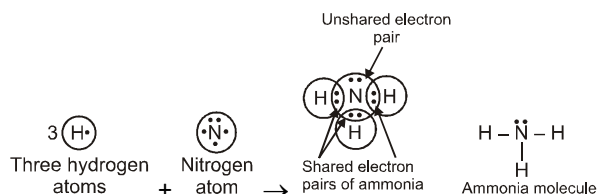

6. Formation of H₂O molecule

The electronic configuration of hydrogen is K (1) and that of oxygen is K(2) L(6). Thus, each hydrogen requires one electron and oxygen requires two electrons to achieve the stable electronic configuration.

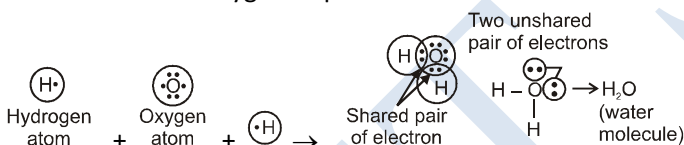

7. Formation of CH₄ molecule

Methane is a covalent compound containing four covalent bonds. It contains one carbon atom and four hydrogen atoms covalently bonded to central carbon atom.

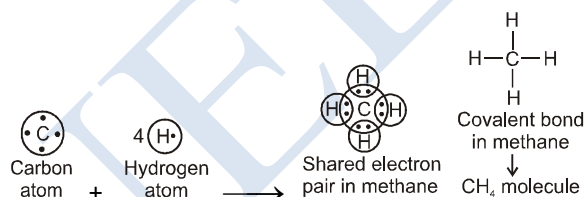

4.3 ALLOTROPES OF CARBON

When an element exists in two or more different forms in the same physical state, these different forms are called allotropes and the phenomenon is known as allotropy.

Allotropes have same chemical properties but they differ in their physical properties.

Carbon exists in two types of allotropic forms. They are crystalline and amorphous. Diamond and graphite are two well known crystalline forms of carbon. A third form of crystalline carbon was discovered by H.W. Kroto, E. Smalley and R.F. Curl. They were awarded Nobel prize in 1996 for the discovery of this allotrope. This form is known as fullerenes.

➤ Structure of Diamond

In diamond, each carbon atom is linked to 4 other carbon atoms by single bonds only. Each carbon atom is present at the centre of a regular tetrahedron and the other 4 carbon atoms linked to it lie to the corners of regular tetrahedron. Thus diamond exists as three dimensional network. Since there are no mobile or free electrons, diamond is a bad conductor of electricity.

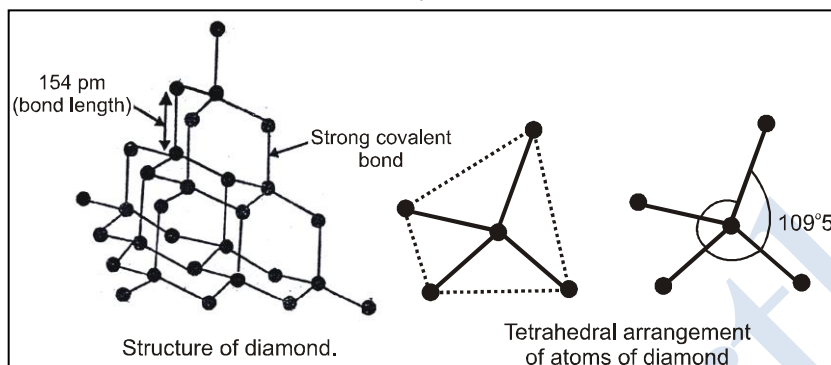

The C – C bond length in diamond is 154 pm. The directional covalent bonds are present throughout the lattice. Since diamond exists as three dimensional network solid, it is the hardest substance on earth. It has high density and melting point.

Uses of Diamond

- Due to its hardness, diamond is used for cutting marble, granite and glass.
- It is used as an abrasive and for polishing hard surfaces.
- Diamond when properly cut brilliant light is refracted from its surface, which makes it a precious gem and jewellery.
- It is used in making special surgical knives.



Think Wise

- Carbon can be one of the least expensive elements (as carbon black or soot) or most expensive (as diamond)

➤ Structure of Graphite

In graphite, each carbon atom is linked to 3 other carbon atoms by single bonds. The fourth electron on each carbon atom results in the formation of π -bond. Graphite has sheet like (layered) structure having hexagonal layers. It has two dimensional structure. The hexagonal rings are fused together and are held together by weak van der Waals forces. One layer slides over the other layer which makes graphite soft in touch. It is the reason that graphite is used as lubricant.

C – C bond length in graphite is 141.5 pm and the distance between two layers is 340 pm.

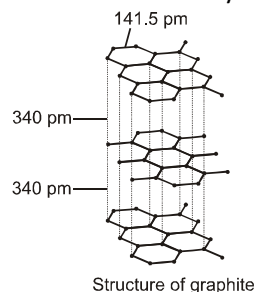
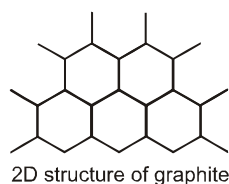

Uses of Graphite

- As a reducing agent in the extraction of metals.
- In making electrodes for electrolytic cells.
- Since graphite is soft and slippery therefore, it is used as a dry lubricant in machines running at high temperature.
- Graphite is also used to moderate the fast moving neutrons.
- Mixed with wax and clay, graphite is used for making cores of lead pencils as it can mark paper black. It is, therefore, often, called plumbago or black lead.
- Graphite crucibles can withstand very high temperature and can be used for high melting substances.



Think Wise

Impure diamonds (black) are used in knives for cutting glass, "Diamond studded saws" in drill bits, as rock borers and is also used as polishers.

| | Diamond | Graphite |
|---|---|--|
| 1 | Diamond has three dimensional rigid structure. | Graphite has layer structure. The layers can slip over one another. |
| 2 | Diamond is hard. It is hardest substance known. | Graphite is soft and greasy. |
| 3 | Diamond is a bad conductor of electricity but good conductor of heat. | Graphite is a good conductor of both electricity and heat. |
| 4 | Diamond has very high density. (3.514 g/cm ³) | Graphite is less dense (density = 2.26 g/cm ³) than diamond. |
| 5 | Diamond is a transparent substance. | Graphite is an opaque substance. |

➤ Structure of Fullerenes

Fullerenes are made by the heating of graphite in an electric arc in the presence of inert gases such as helium or argon. The sooty material formed by condensation of vapourised C_n small molecules consists of mainly C₆₀ with smaller quantity of C₇₀ and traces of fullerenes consisting of even number of carbon atoms upto 350 or above. Fullerenes are the only pure form of carbon because they have smooth structure without having 'dangling' bonds. Fullerenes are cage like molecules. C₆₀ molecules has a shape like soccer ball and called Buckminsterfullerene.

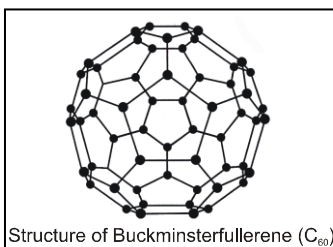

It contains twenty six-membered ring and twelve five membered ring. A six-membered ring is fused with six or five members ring but a five-membered ring can only fuse with six-membered ring.

Each carbon atom forms three sigma bonds with other three carbon atoms.

The remaining electron at each carbon is free and can move throughout the structure of graphite. This ball shaped molecule has 60 vertices and each one is occupied by one carbon atom and it also contains both single and double bonds with C — C distances of 143.5 pm and 138.3 pm respectively. Spherical fullerenes are also called bucky balls in short. The name Buckminsterfullerene was given in the honour of American architect Robert Buckminster Fuller who designed geodesic dome structures.

Uses of Fullerenes

- Fullerenes in pure state act as insulators but can be converted to semiconductors and superconductors under suitable conditions.
- Fullerenes help in improving antiwear and antifriction properties of lubricating oils.
- Bucky ball's ability of fullerenes to trap different atoms or molecules makes them useful in the medical field. For example, radioactive C_{60} can be used in cancer as well as in AIDS therapy.
- Fullerenes in small amounts can catalyse the photochemical refining in industry.



Think Wise

Buckyballs have been found to inhibit the spread of HIV, according to a study published in 2009 in the Journal of Chemical Information and Modeling; medical researchers are working to attach drugs, molecule-by-molecule, to buckyballs in order to deliver medicine directly to sites of infection or tumors in the body; this includes research by Columbia University, Rice University and others.

➤ Amorphous Forms of Carbon

Carbon black, coke and charcoal are all impure forms of graphite or fullerenes.

- **Coke** : Coal is subjected to destructive distillation for the manufacture of oil gas. Coke is left as residue in the retort. It is a greyish hard solid.
- **Charcoal** : It is a black, soft and highly porous substance. It exists in following forms :
 - (i) wood charcoal, (ii) animal charcoal and (iii) sugar charcoal
 - Wood charcoal : It is obtained by heating wood in a limited supply of air.
 - Animal charcoal : It is also called bone charcoal. It is obtained by the destructive distillation of bones. It contains 10% to 20% carbon rest is calcium phosphate.
 - Sugar charcoal : It is obtained by the action of conc. H_2SO_4 on sugar.

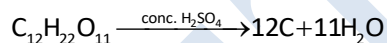

- **Carbon black or lamp black** : It is obtained by heating rich hydrocarbons in limited supply of air.



Animal charcoal and sugar charcoal are used to remove colouring matter.



Think Wise

- The youngest member of the carbon family is graphene, found by chance in 2004 by Andre Geim and Kostya Novoselov.
- Graphene is a sheet of carbon only one atom thick. It's the strongest material known while still being ultralight and flexible. And it conducts electricity better than copper.

➤ Uses of Carbon

- Graphite fibres embedded in plastic material form high strength, light weight composite. The composites are used in products such as tennis racquets, fishing rods, aircraft and canoes.
- Being good conductor, graphite is used for electrodes in batteries and industrial electrolysis.
- Being highly porous, activated charcoal is used in adsorbing poisonous gases; also used in water filters to remove organic contaminants and in air-conditioning systems to control odour.
- Carbon black is used as black pigment in black ink and as filler in automobile tyres.
- Coke is used as fuel and largely as a reducing agent in metallurgy.
- Diamond is a precious stone and used in jewellery. It is measured in carats (1 carat = 200 mg).



Think Wise

A carbon nanotube (CNT) is a minuscule, straw-like structure made of carbon atoms. These tubes are extremely useful in a wide variety of electronic, magnetic and mechanical technologies. The diameters of these tubes are so tiny that they are measured in nanometers. A nanometer is one-billionth of a meter — about 10,000 times smaller than a human hair.

4.4 VERSATILE NATURE OF CARBON

About three million (or thirty lakh) compounds of carbon are known. The existence of such a large number of organic compounds is due to the following characteristic features of carbon.

(i) Catenation : Tendency to form carbon-carbon bond

“The property of forming bonds with atoms of the same element is called catenation”.

Carbon has the maximum tendency of catenation in the periodic table. This is because of strong carbon-carbon bonds as compared to other atoms.

No other element exhibits the property of catenation to the extent seen in carbon compounds. Silicon forms compounds with hydrogen which have chains of upto seven or eight atoms, but these compounds are very reactive. The carbon-carbon bond is very strong and hence stable. This gives us the large number of compounds with many carbon atoms linked to each other.

When two or more carbon atoms combine with one another, they form different types of chains such as,

- (i) Straight chains (ii) Branched chains (iii) Closed chain or ring chains

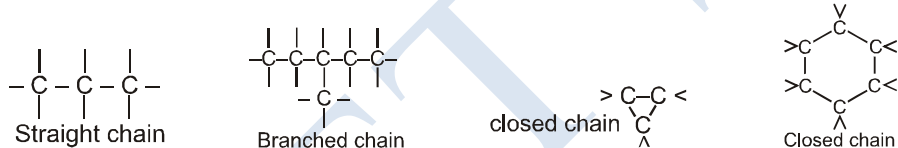

(Minimum 3C required in closed chain structure)

(ii) Tetravalency of carbon

The atomic number of carbon is 6, and hence its electronic configuration of carbon atom is 2, 4.

It has four electrons in the outermost shell, therefore its valency is four (tetravalency). Thus, carbon forms four covalent bonds in its compounds. Compounds of carbon are formed with oxygen, hydrogen, nitrogen, sulphur, chlorine and many other elements giving rise to compounds with specific properties, which depends upon the elements other than carbon present in the molecule.

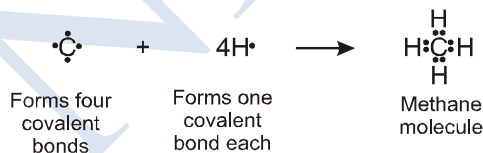

(iii) Tendency to form multiple bonds

Due to small size, carbon can easily form double or triple bonds (called multiple bonds) with itself and with the atoms of other elements as nitrogen, oxygen, sulphur etc.

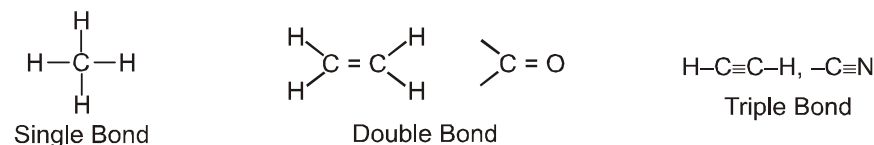

(iv) Isomerism

Compounds having same molecular formula but different structural formulae are known as isomers and the phenomenon of existence of isomers is termed as isomerism.

Example

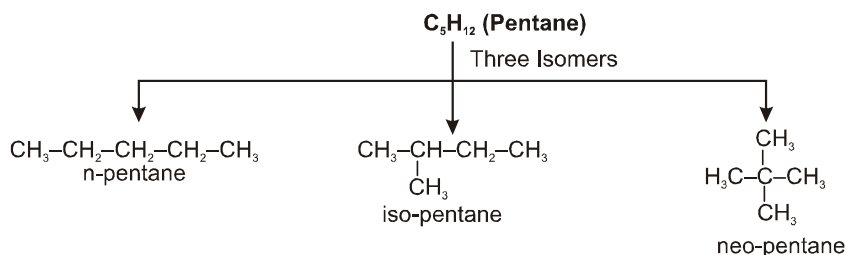
**4.5 ORGANIC COMPOUNDS**

Because of versatile nature of carbon, it forms many compounds. In eighteenth century all known compounds were divided into two categories.

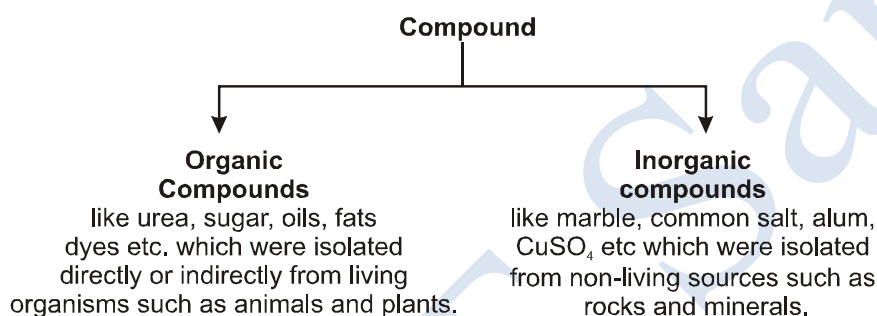

- Vital force theory**

This theory was given by **Berzelius** in 1815.

According to him, organic compounds are produced only under the influence of some mysterious force existing in the living organism. This mysterious force was called the **vital force**.

So, it was believed that no organic compound can be prepared in the laboratory.

- Wohler's synthesis**

Berzelius's theory was disapproved by Friedrich Wohler in 1828 by preparing urea from ammonium cyanate (NH₄CNO) in laboratory.

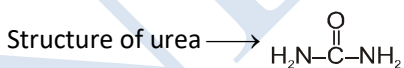

- Modern definition of organic compounds**

Compounds of carbon, containing usually hydrogen and one and more other element such as oxygen, nitrogen, sulphur, halogens, phosphorus etc. are called organic compounds.

4.6 SATURATED AND UNSATURATED HYDROCARBON

On the basis of bonding carbon compounds can be classified in two categories :-

- (i) Saturated hydrocarbon
- (ii) Unsaturated hydrocarbons

(i) Saturated Hydrocarbon

The hydrocarbons which contain only single carbon-carbon covalent bonds are called saturated hydrocarbons.

They are also called alkanes.

General formula for alkanes is C_nH_{2n+2} where 'n' is the number of carbon atoms.

| No. of 'C' atoms | Name | Formula | Structure |
|------------------|---------|-------------|--|
| 1 | Methane | CH_4 | <pre> H H-C-H H </pre> |
| 2 | Ethane | C_2H_6 | <pre> H H H-C-C-H H H </pre> |
| 3 | Propane | C_3H_8 | <pre> H H H H-C-C-C-H H H H </pre> |
| 4 | Butane | C_4H_{10} | <pre> H H H H H-C-C-C-C-H H H H H </pre> |
| 5 | Pentane | C_5H_{12} | <pre> H H H H H H-C-C-C-C-C-H H H H H H </pre> |
| 6 | Hexane | C_6H_{14} | <pre> H H H H H H H-C-C-C-C-C-C-H H H H H H H </pre> |

Ex. Structure of methane CH_4

Methane consists of one carbon and four hydrogen atoms, which are covalently bonded to each others, forming following structure.

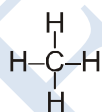
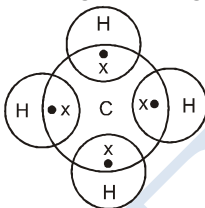

Ex. Structure of ethane C_2H_6

To derive the structure of ethane, the following steps are followed.

Step-I : Link the two carbon atoms.

Carbon atoms are linked together with a single bond.



Step-II : Three valencies of each carbon atom remain unsatisfied, so each is bonded to three hydrogen atoms giving the following structure.

Each carbon atom is bonded to three hydrogen atoms.

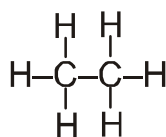
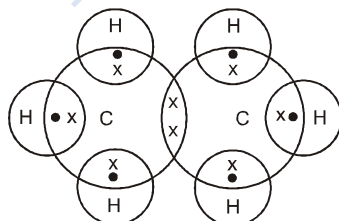

Lewis dot structure of ethane

Ex. Structure of propane C₃H₈

In a similar manner we can derive the structure of propane.

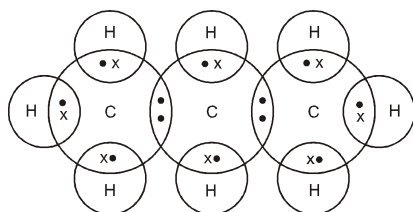

Lewis dot structure of propane

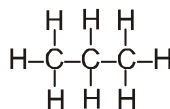
(ii) Unsaturated hydrocarbons

The hydrocarbons in which two carbon atoms are bonded to each other by a double (=) or a triple (\equiv) bond is called an unsaturated hydrocarbon. Unsaturated hydrocarbons are of two types viz. alkenes and alkynes.

(a) Alkenes ($-\overset{\text{C}}{\text{C}}-$)

The hydrocarbons in which the two carbon atoms are bonded by a double bond are called alkenes.

Their general formula is C_nH_{2n} where “n” is the number of carbon atoms.

General formula of alkenes : C_nH_{2n}

| No. of 'C' atoms | Name | Formula | Structure |
|------------------|---------|---|--|
| 2 | Ethene | C ₂ H ₄ CH ₂ =CH ₂ | $ \begin{array}{c} \text{H} \quad \text{H} \\ \diagdown \quad \diagup \\ \text{C}=\text{C} \\ \diagup \quad \diagdown \\ \text{H} \quad \text{H} \end{array} $ |
| 3 | Propene | C ₃ H ₆ CH ₃ -CH=CH ₂ | $ \begin{array}{c} \text{H} \quad \text{H} \quad \text{H} \\ \quad \quad \\ \text{H}-\text{C}-\text{C}=\text{C}-\text{H} \\ \\ \text{H} \end{array} $ |
| 4 | Butene | C ₄ H ₈ CH ₃ -CH=CH-CH ₃ or CH ₂ =CH-CH ₂ -CH ₃ | $ \begin{array}{c} \text{H} \quad \text{H} \quad \text{H} \quad \text{H} \\ \quad \quad \quad \\ \text{H}-\text{C}-\text{C}=\text{C}-\text{C}-\text{H} \\ \quad \quad \quad \\ \text{H} \quad \quad \quad \text{H} \end{array} $ or $ \begin{array}{c} \text{H} \quad \text{H} \quad \text{H} \quad \text{H} \\ \quad \quad \quad \\ \text{H}-\text{C}=\text{C}-\text{C}-\text{C}-\text{H} \\ \quad \quad \quad \quad \\ \quad \quad \quad \text{H} \quad \text{H} \end{array} $ |

Ex. Formation of ethene molecule (C₂H₄)

The electronic configuration of carbon atom is 2, 4. There are four valence electrons in one C atom. Each H atom contains one valence electron.

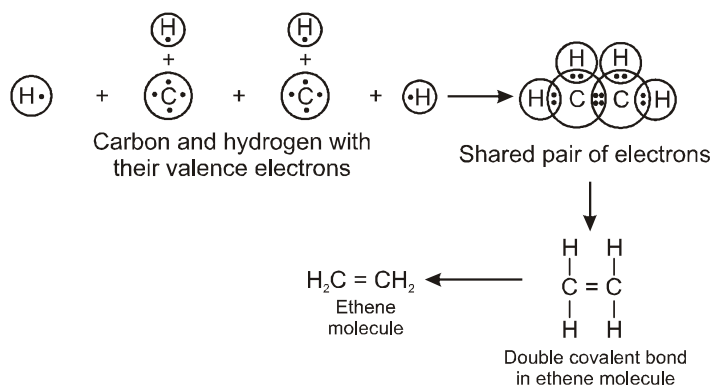

(b) Alkyne ($-\text{C}\equiv\text{C}-$)

The hydrocarbons in which two carbon atoms are bonded by a triple bond are called alkynes.

Their general formula is $\text{C}_n\text{H}_{2n-2}$ where 'n' is the number of carbon atoms.

General formula of alkynes : $\text{C}_n\text{H}_{2n-2}$

| No. of 'C' atoms | Name | Formula | Structure |
|------------------|---------|--|---|
| 2 | Ethyne | C_2H_2 or $\text{HC}\equiv\text{CH}$ | $\text{H}-\text{C}\equiv\text{C}-\text{H}$ |
| 3 | Propyne | C_3H_4 or $\text{H}_3\text{C}-\text{C}\equiv\text{C}-\text{H}$ | $\begin{array}{c} \text{H} \\ \\ \text{H}-\text{C}-\text{C}\equiv\text{C}-\text{H} \\ \\ \text{H} \end{array}$ |
| 4 | Butyne | C_4H_6 or $\text{H}_3\text{C}-\text{C}\equiv\text{C}-\text{CH}_3$ | $\begin{array}{c} \text{H} \qquad \qquad \text{H} \\ \qquad \qquad \quad \\ \text{H}-\text{C}-\text{C}\equiv\text{C}-\text{C}-\text{H} \\ \qquad \qquad \quad \\ \text{H} \qquad \qquad \quad \text{H} \end{array}$ |

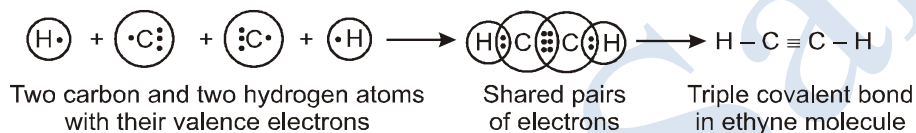
Formation of ethyne molecule (C_2H_2)

4.7 CHAINS, BRANCHES AND RINGS

On the basis of structure carbon compounds can be divided into 3 categories :-

- Straight chain compounds
- Branched chain compounds
- Closed chain / cyclic / ringed compounds

(a) Straight chain compounds

If a carbon compound has carbon-carbon link in chain fashion, we get a straight chain compound.

In these, a carbon can form bond with a maximum of 2 carbon atoms e.g.

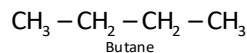
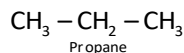
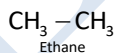
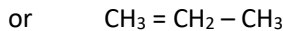
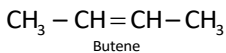
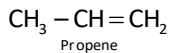
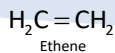
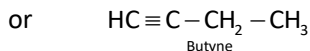
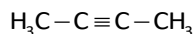
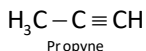
(i) Straight chain alkanes

(ii) Straight chain alkenes

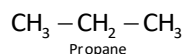
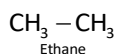
(iii) Straight chain alkynes

(b) Branched structure

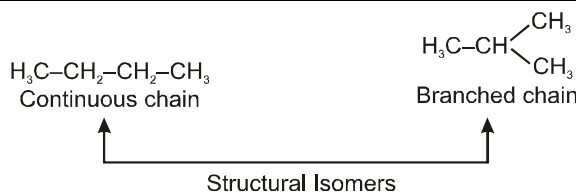
The alkanes containing three or less carbon atoms do not form branches.



The alkane containing four carbon atoms (C_4H_{10}) has two types of arrangement of carbon atoms.



Thus carbon compounds in which atleast one carbon of the chain is linked to three or four other carbon atoms are called branched chain compounds.

Like saturated compounds, unsaturated compounds can also have branched chain structure e.g. C_4H_8 , butene may have following structure.

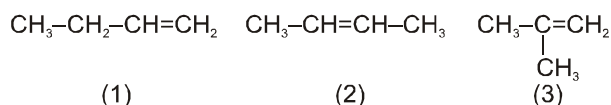

Among these three, (1) and (2) are straight chains while (3) is a branched chain.

(c) Closed chains or cyclic hydrocarbons or ring hydrocarbons

These hydrocarbons contains closed chain or ring of atoms in their molecules. These can be of further two types :

(i) Alicyclic hydrocarbon or saturated cyclic carbon compounds or cycloalkanes

These hydrocarbons contain a ring chain of three or more carbon atoms. These cyclic compounds are named by prefixing 'cyclo' before the name of corresponding straight chain hydrocarbon.

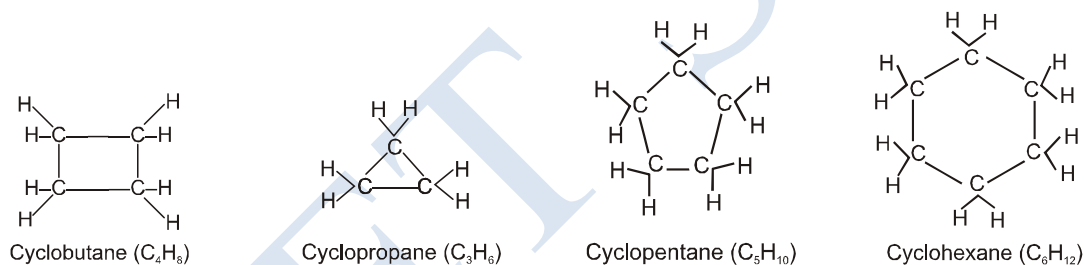

(ii) Aromatic hydrocarbon or Unsaturated cyclic carbon compound

These have at least one benzene ring in their molecules.

It is special type of ring of six carbon atoms with three double bonds in alternative positions.

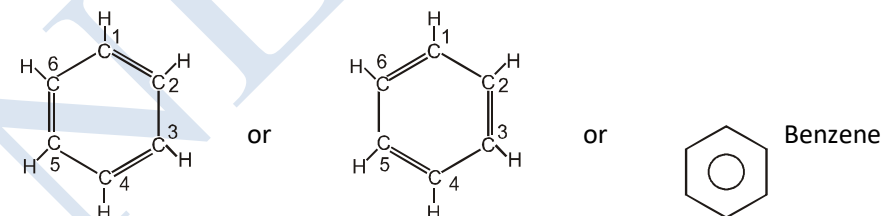

4.8 FUNCTIONAL GROUPS

In organic chemistry, functional groups (or moieties) are specific groups of atoms within molecules that are responsible for the characteristic chemical reactions of those molecules. The same functional group will undergo the same or similar reaction(s) regardless of the size of the molecule it is a part of.

Combining the names of functional groups with the names of the parent alkanes generates a powerful systematic nomenclature for naming organic compounds.

The non-hydrogen atoms of functional groups are always associated with each other and with the rest of the molecule by covalent bonds.

The first carbon atom after the carbon that attaches to the functional group is called the alpha carbon. Functional groups are attached to the carbon backbone or organic molecules. They determine the characteristics and chemical reactivity of molecules. Functional groups are far less stable than the carbon backbone and are likely to participate in chemical reactions. Free valency or valencies of the group are shown by the single line. The functional group is attached to the carbon chain through this valency by replacing one hydrogen atom or atoms.

Important Functional Groups and the Corresponding Classes or Organic Compounds :

| S.No. | Functional Group | | Class of compounds |
|-------|------------------------|------------------------------------|------------------------------------|
| | Formula | Name | |
| 1 | -X (-F, Cl, -Br, -I) | Halo (fluoro, chloro, bromo, iodo) | Alkyl halides or halogen compounds |
| 2 | -OH | Hydroxy | Alcohol |
| 3 | -OR | Alkoxy | Ethers |
| 4 | -SH | Mercapto | Thioalcohols, mercaptans or thiols |
| 5 | -SR | | Thioethers or sulphides |
| 6 | -CHO | Aldehydic | Aldehydes |
| 7 | -CO- | Ketonic | Ketones |
| 8 | -COOH | Carboxyl | Carboxylic acids |
| 9 | -COOR | Ester | Esters |
| 10 | -COX (X = Cl, Br or I) | Acyl halide | Acid halides or Acyl halides |
| 11 | -CONH ₂ | Amide | Amides or acid amides |
| 12 | -CO.O.CO- | Anhydride | Acid anhydrides |
| 13 | -NH ₂ | Amino | Amines |
| 14 | -NH- | Imino | Imines |
| 15 | -C ≡ N | Cyano | Cyanides or Nitriles |
| 16 | -N ≡ C | Isocyano | Isocyanides or Isonitriles |
| 17 | -NO ₂ | Nitro | Nitro compounds |
| 18 | -N = O | Nitroso | Nitroso compounds |
| 19 | -N = N- | Azo | Azo compounds |
| 20 | -SO ₂ -OH | Sulphonic acid | Sulphonic acids |

4.9 HOMOLOGOUS SERIES

Definition : "A series of organic compounds having similar functional groups and similar chemical properties in which the successive members differ in their molecular formula by -CH₂ group".

The different members of the series are called as homologous characteristic of homologous series

- All the members of a homologous series can be described by a common general formula.
Example : All alkane can be described by the general formula C_nH_{2n+2}.
- Each member of a homologous series differs from its higher and lower neighbouring member by a common difference of -CH₂ group.
- Molecular masses of the two adjacent homologues differ by 14 mass units, because molecular mass of -CH₂ group is 12 + 2 = 14.
- All the members of a homologous series show similar chemical properties e.g. substitution reaction is shown by all alkanes.
- All the members of a homologous series show a gradation in physical properties as molecular mass increases. e.g. M.P. and B.P. increases with increase in molecular mass.
- All the members of the series can be prepared by similar methods known as the general method of preparation.

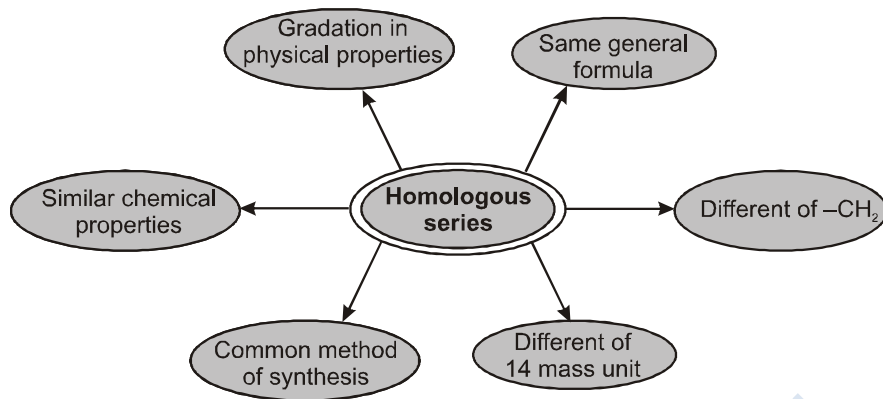

Fig. Some members of alkane, alkene and alkyne homologous series

| Alkane (C_nH_{2n+2}) Homologous series | | Alkene (C_nH_{2n}) Homologous series | | Alkyne (C_nH_{2n-2}) Homologous series | |
|--|-------------|--|-------------|--|-------------|
| Name | Formula | Name | Formula | Name | Formula |
| Methane | CH_4 | – | – | – | – |
| Ethane | C_2H_6 | Ethene | C_2H_4 | Ethyne | C_2H_2 |
| Propane | C_3H_8 | Propene | C_3H_6 | Propyne | C_3H_4 |
| Butane | C_4H_{10} | Butene | C_4H_8 | Butyne | C_4H_6 |
| Pentane | C_5H_{12} | Pentene | C_5H_{10} | Pentyne | C_5H_8 |
| Hexane | C_6H_{14} | Hexene | C_6H_{12} | Hexyne | C_6H_{10} |

4.10 NOMENCLATURE OF CARBON COMPOUNDS

Nomenclature means the assignment of names to organic compounds. There are two main systems of nomenclature of organic compounds -

➤ **Basic rules of IUPAC nomenclature of organic compounds :**

For naming simple aliphatic compounds, the normal saturated hydrocarbons have been considered as the parent compounds and the other compounds as their derivatives obtained by the replacement of one or more hydrogen atoms with various functional groups.

(i) Each systematic name has two or three of the following parts -

- **Word root :** The basic unit of a series is word root which indicate linear or continuous number of carbon atoms.
- **Primary suffix :** Primary suffixes are added to the word root to show saturation or unsaturation in a carbon chain.
- **Secondary suffix :** Suffixes added after the primary suffix to indicate the presence of a particular functional group in the carbon chain are known as secondary suffixes.

(ii) **Names of straight chain hydrocarbons :** The name of straight chain hydrocarbon may be divided into two parts -

(A) Word root

(B) Primary suffix

(A) Word roots for carbon chain lengths

| Chain length | Word root | Chain length | Word root |
|----------------|-----------|-----------------|-----------|
| C ₁ | Meth - | C ₆ | Hex - |
| C ₂ | Eth - | C ₇ | Hept - |
| C ₃ | Prop - | C ₈ | Oct - |
| C ₄ | But - | C ₉ | Non - |
| C ₅ | Pent - | C ₁₀ | Dec - |

(B) Primary suffix :

| Class of compounds | Primary suffix | General name |
|--|----------------|--------------|
| $\begin{array}{c} \diagup \text{C} - \text{C} \diagdown \\ \text{saturated} \end{array}$ | - ane | Alkane |
| $\begin{array}{c} \diagup \text{C} = \text{C} \diagdown \\ \text{Unsaturated} \end{array}$ | - ene | Alkene |
| $\begin{array}{c} - \text{C} \equiv \text{C} - \\ \text{Unsaturated} \end{array}$ | - yne | Alkyne |

Examples :

| Molecular formula | Word root | Primary suffix | IUPAC Name |
|---|-----------|----------------|------------|
| CH ₄ | Meth- | - ane | Methane |
| CH ₃ - CH ₃ | Eth- | - ane | Ethane |
| CH ₃ CH ₂ CH ₃ | prop- | - ane | Propane |
| CH ₃ CH ₂ CH ₂ CH ₃ | But- | - ane | Butane |
| CH ₂ = CH ₂ | Eth- | - ene | Ethene |
| CH ₃ - CH = CH ₂ | Prop- | - ene | Propene |
| CH ₃ - C \equiv CH | Prop- | - yne | Propyne |

❖ **Note :**

The name of the compound, in general, is written in the following sequence - (Position of substituents) - (prefixes) (word root)- (primary - suffix).

(iii) Name of branched chain hydrocarbon : The carbon atoms in branched chain hydrocarbons are present as side chain. These side chain carbon atoms constitute the alkyl group or alkyl radicals. An alkyl group is obtained from an alkane by removal of a hydrogen.

General formula of alkyl group = C_nH_{2n+1}

- **An alkyl group is represented by R.**

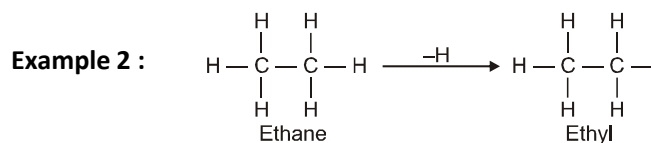
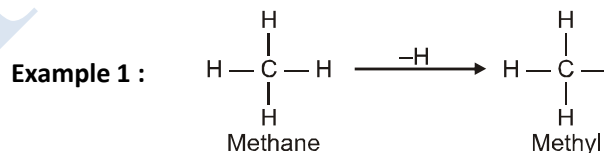

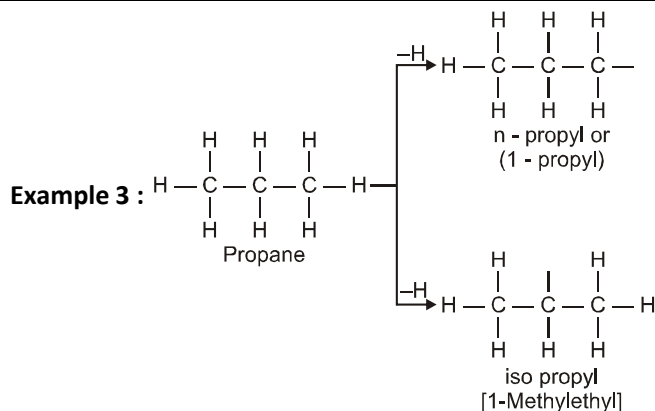

➤ A branched chain hydrocarbon is named using the following general IUPAC rules :

Rule 1 : Longest chain rule : Select the longest possible continuous chain of carbon atoms. If some multiple bond is present, the chain selected must contain the multiple bond.

- The number of carbon atoms in the selected chain determines the word root.
- Saturation or unsaturation determines the primary suffix (P. suffix).
- Alkyl substituents are indicated by prefixes.

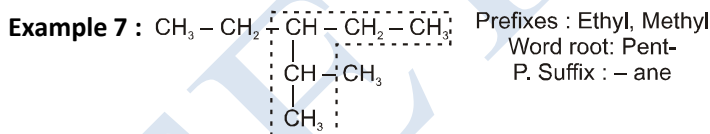
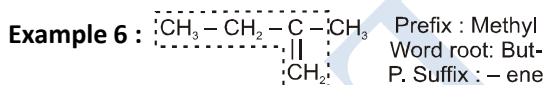
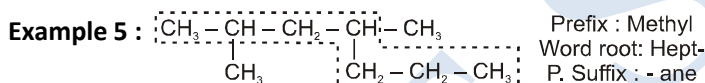
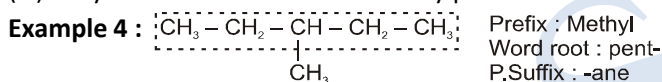

Rule 2 : Lowest number rule : The chain selected is numbered in terms of arabic numerals and the position of the alkyl group are indicated by the number of the carbon atom to which alkyl group is attached.

- The numbering is done in such a way that the substituent carbon atom has the lowest possible number.
- If some multiple bond is present in the chain, the carbon atoms involved in the multiple bond should get lowest possible numbers.

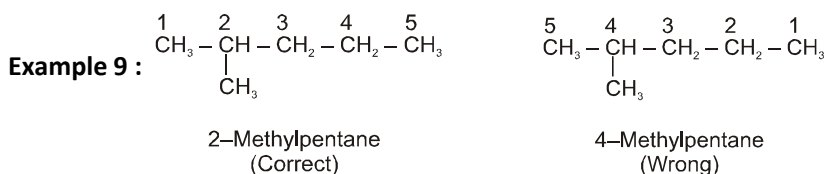
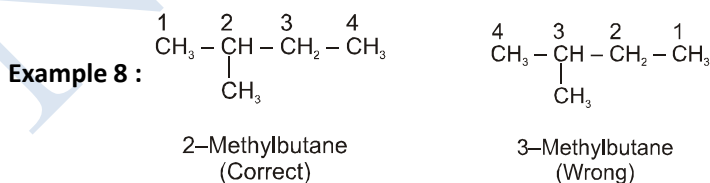

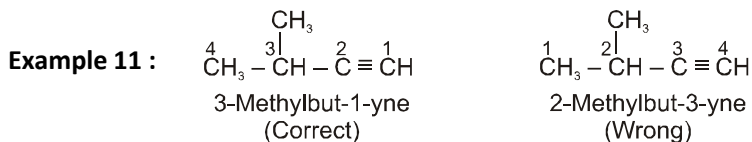
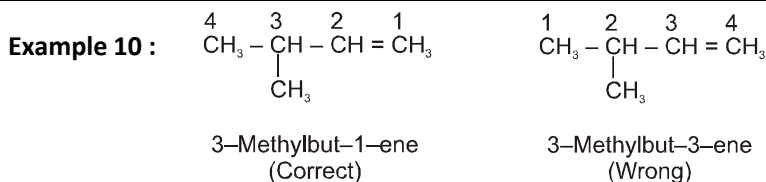

Rule 3 : Use of prefixes di, tri etc. : If the compound contains more than one similar alkyl groups, their positions are indicated separately and an appropriate numerical prefix di, tri etc. , is attached to the name of the substituents. The positions of the substituents are separated by commas.

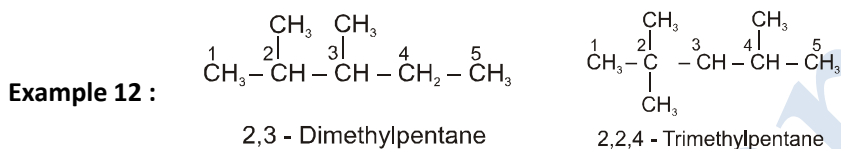

Rule 4 : Alphabetical arrangement of prefixes : If there are different alkyl substituents present in the compound their names are written in the alphabetical order. However, the numerical prefixes such as di, tri etc. are not considered for the alphabetical order.

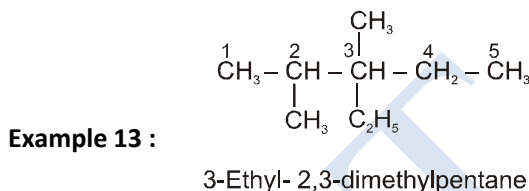

Rule 5 : Naming of different alkyl substituents at the equivalent positions :

Numbering of the chain is done in such a way that the alkyl group which comes first in alphabetical order gets the lower position.

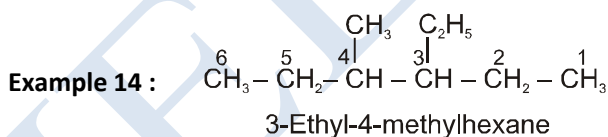

Rule 6 : Lowest sum rule :

According to this rule numbering of chain is done in such a way that the sum of positions of different substituents gets lower value.

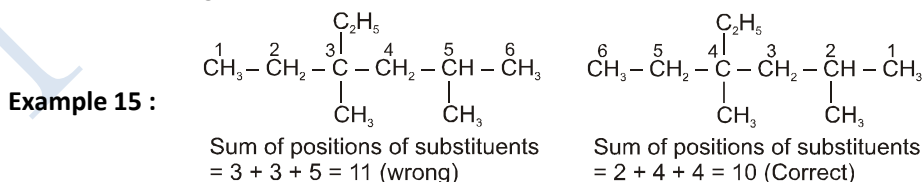

Word root : Hex-
Primary suffix : -ane
Substituent : two methyl groups
IUPAC name : 4 - Ethyl - 2, 4 - dimethyl hexane

Some other examples :

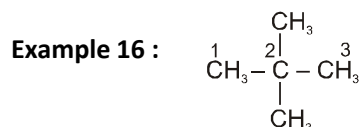

Word root : Prop -
 P. Suffix : -ane
 Substituent : two methyl groups
 IUPAC name : 2,2, - Dimethylpropane

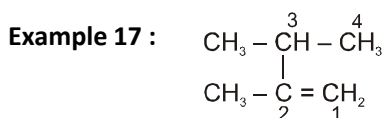

Word root : But -
 P. Suffix : -ene
 Substituent : two methyl groups
 IUPAC name : 2,3 - Dimethylbut - 1 - ene

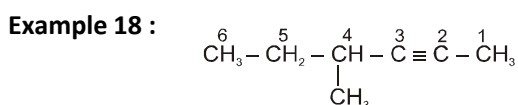

Word root : Hex -
 P. Suffix : -yne
 Substituent : one methyl group
 IUPAC name: 4 - Methylhex - 2 - yne

4.10.1 NOMENCLATURE OF COMPOUNDS CONTAINING FUNCTIONAL GROUP

In case some functional group (other than C = C and C ≡ C) is present in molecule, it is indicated by adding secondary suffix after the primary suffix. The terminal 'e' of the primary suffix is generally removed before adding the secondary suffix. The terminal 'e' of the primary suffix is removed if it is followed by a suffix beginning with 'a', 'i', 'o', 'u' or 'y'.

Some functional groups (such as -OR) are indicated by the prefixes. The various classes of organic compounds, their functional groups, the secondary suffixes (or prefixes) used to indicate them along with their general IUPAC names, are given in table. It may be mentioned here that the groups -NO₂, -OR, -F, -Cl, -Br and -I are considered as substituents and are indicated by prefixes and the groups -CONH₂, -COOR, -NH₂, -CN and -OH are considered as functional groups and are indicated by suffixes.

Different Functional Groups and Corresponding Suffixes and Prefixes

| S. No. | Functional group | Prefix | Suffix |
|--------|---|-----------------------|------------------------|
| 1. | –(C) OOH (carboxylic acid) | × | oic acid |
| | – COOH | carboxy | carboxylic acid |
| 2. | – SO ₃ H (sulphonic acid) | sulpho | sulphonic acid |
| 3. | $\begin{array}{c} \text{O} \\ \parallel \\ \text{-(C)} \\ \diagup \quad \diagdown \\ \text{O} \quad \text{O} \end{array}$ (anhydride) | × | oic anhydride |
| 4. | – (C)OOR (ester) | × | alkyl oate |
| | – COOR | alkoxy carbonyl | alkyl..... carboxylate |
| 5. | – (C)OX (acid halide) | × | oyl halide |
| | –COX | halo formyl | carbonyl halide |
| 6. | $\begin{array}{c} \text{-(C)O} \\ \\ \text{N-} \end{array}$ (amide) | × | amide |
| | $\begin{array}{c} \text{-(C)O} \\ \\ \text{N-} \end{array}$ | carbamoyl / Amido | carboxamide |
| 7. | –(C)N (cyanide) | × | Nitrile |
| | –CN | cyano | carbonitrile |
| 8. | –N ≡ C (isocyanide) | isocyano/carbyl amino | isonitrile |
| 9. | –(C)HO (aldehyde) | oxo | al |
| | –CHO | formyl | carbaldehyde |
| 10. | $\begin{array}{c} \text{-(C)-(Ketone)} \\ \parallel \\ \text{O} \end{array}$ | keto/oxo | one |
| 11. | –OH (alcohol) | hydroxy | ol |
| 12. | – SH (thio alcohol) | mercapto | thiol |
| 13. | $\begin{array}{c} \text{-N-} \\ \\ \text{I} \end{array}$ (amine) | amino | amine |

* (C) → It means this carbon is included in principal carbon chain.

Steps of naming of an organic compound containing functional group :

Step 1 : Select the longest continuous chain of the carbon atoms as parent chain. The selected chain must include the carbon atoms involved in the functional groups like –COOH, –CHO, –CN etc, or those which carry the functional groups like –OH, –NH₂, –Cl, –NO₂ etc.

The number of carbon atoms in the parent chain decides the word root.

Step 2 : The presence of carbon - carbon multiple bond decides the primary suffix.

Step 3 : The secondary suffix is decided by the functional group.

Step 4 : The carbon atoms of the parent chain are numbered in such a way so that the carbon atom of the functional group gets the lowest possible number. In case the functional group does not have the carbon atom, then the carbon atom of the parent chain attached to the functional group should get the lowest possible number.

Step 5 : The name of the compound is written as - Prefixes - word root - primary suffix - secondary suffix

❖ **Note** The number of carbon atoms in the parent chain decides the word root.

Some more examples :

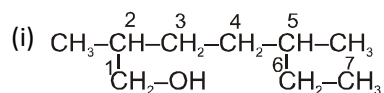

Word root : Hept-
 Primary suffix : -ane
 Functional group : -OH
 Secondary suffix : -ol
IUPAC Name : 2, 5-Dimethylheptan-1-ol

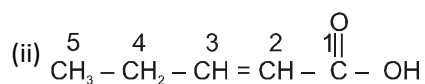

Word root : Pent-
 Primary suffix : -ene
 Secondary suffix : -oic acid
IUPAC Name : Pent-2-en-1-oic acid/ Pent-2-enoic acid

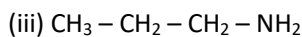

Word root : Prop -
 Primary suffix : -ane
 Secondary suffix : -amine
IUPAC Name : Propan - 1 - amine

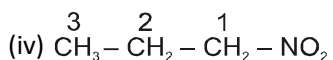

Word root : Prop -
 Primary suffix : -ane
 Secondary suffix : -nitro(prefix)
IUPAC Name : 1 - Nitropropane

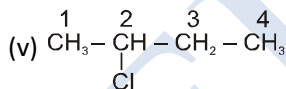

Word root : But -
 Primary suffix : -ane
 Prefix : -chloro
IUPAC Name : 2 - Chlorobutane



JEE - CHECK POINT

Q. Which compounds 2,2,3-trimethyl hexane ?

[IIT - JEE, 1986]

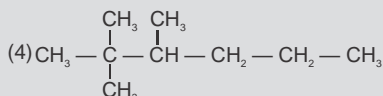
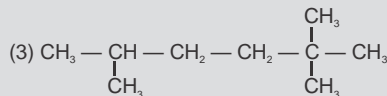
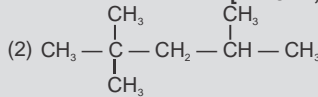
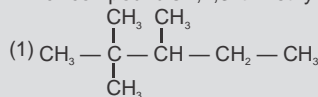

A. (4)

Q. The number of σ - and π - bonds in 1-buten-3-yne is :

[IIT - JEE, 1989]

(1) 5σ and 5π

(2) 7σ and 3π

(3) 8σ and 2π

(4) 6σ and 4π

A. (2)

Q. The correct IUPAC name of the compound is :

[IIT - JEE, 1990]

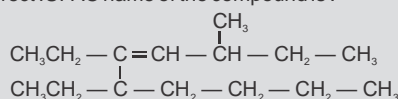

(1) 5, 6 - Diethyl - 3 - methyl dec - 4 - ene

(2) 5, 6 - diethyl - 8 methyl dec - 6 ene

(3) 6 - Butyl - 5 - ethyl - 3 - methyl oct - 4 - ene

(4) 2, 4, 5 - Triethyl - 3 - nonene

A. (1)

Q. The IUPAC name of $(\text{CH}_3)_3\text{C} - \text{CH} = \text{CH}_2$ is :

[IIT - JEE, 1984]

(1) 2, 2 - Dimethyl but - 3 - ene

(2) 2, 2 - Dimethyl pent - 4 - ene

(3) 3, 3 - Dimethyl but - 1 - ene

(4) Hex - 1 - ene

A. (3)



NEET - CHECK POINT

Q. The IUPAC name of the compound is :-

[NEET - 2017]

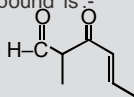

(1) 5-formylhex-2-en-3-one

(2) 5-methyl-4-oxohex-2-en-5-al

(3) 3-keto-2-methylhex-5-enal

(4) 3-keto-2-methylhex-4-enal

A. (4)

Q. Structure of the compound whose IUPAC name is 3-Ethyl-2-hydroxy-4-methylhex-3-en-5-ynoic acid is :-

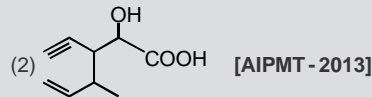
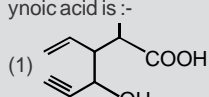

[AIPMT - 2013]

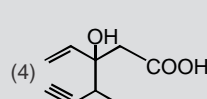
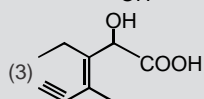

A. (3)

Q. The IUPAC name of the following compound is :-

[AIPMT - 2011]

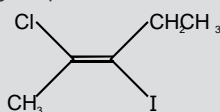

(1) cis-2-chloro-3-iodo-2-pentene

(2) trans-2-chloro-3-iodo-2-pentene

(3) cis-3-iodo-4-chloro-3-pentene

(4) trans-3-iodo-4-chloro-3-pentene

A. (2)

NEET - CHECK POINT

Q. The correct IUPAC name of the compound is :-

[AIPMT - 2011]

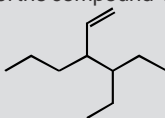

- (1) 4-Ethyl-3-propyl hex-1-ene (2) 3-Ethyl-4-ethenyl heptane
 (3) 3-Ethyl-4-propyl hex-5-ene (4) 3-(1-ethyl propyl) hex-1-ene

A. (1)

Q. The IUPAC name of the compound having the formula $\text{CH} \equiv \text{C} - \text{CH} = \text{CH}_2$ is :- [AIPMT - 2009]

- (1) 1-butene-3-yne (2) 3-buten-1-yne (3) 1-butyne-3-ene (4) but-1-yn-3-ene

A. (1)

4.11 ISOMERISM

Such compounds which have same molecular formula but different physical and chemical properties are known as isomers and the phenomenon is isomerism.

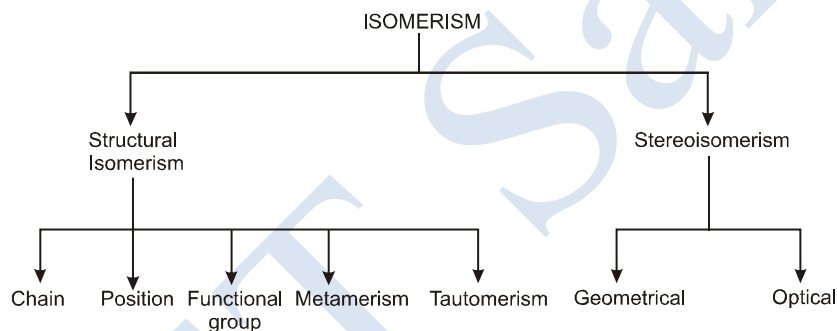

(a) Chain Isomerism :

The isomerism in which the isomers differ from each other due to the presence of different carbon chain skeletons is known as chain isomerism.

e.g.

(i) C_4H_{10}

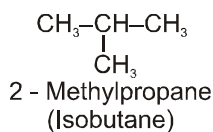
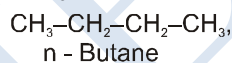

(ii) C_5H_{12}

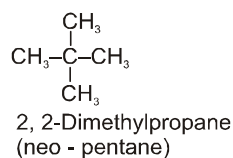
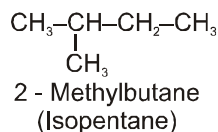
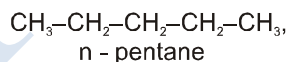

(iii) C_4H_8

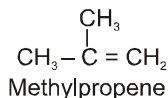
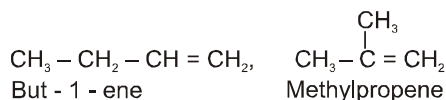

(iii) Burning of LPG (Butane) produces CO₂, H₂O, heat and light.

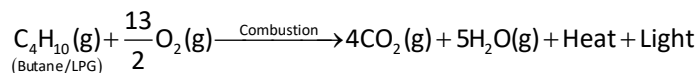

(iv) Combustion of alcohol

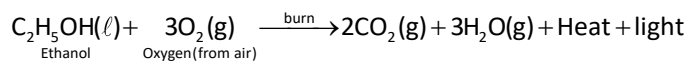

2. Oxidation reaction

Addition of oxygen or removal of hydrogen is called oxidation and the substances which are capable of adding oxygen to other substances are called oxidising agents.

- Carbon gives carbon monoxide or carbon dioxide depending upon the oxygen available.

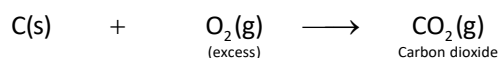
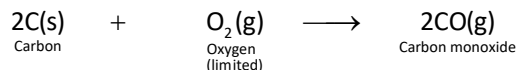

Hydrocarbon when oxidised give different product as follows :

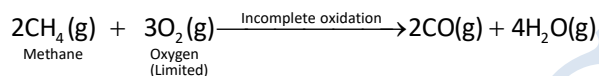
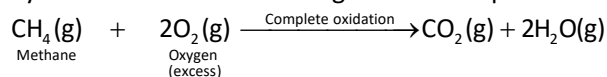

- Alcohols also give different products on oxidation depending upon the reaction conditions.

Example :

(i) Alcohols on oxidation with certain oxidising agents such as chromic anhydride in acetic acid, yield corresponding aldehydes.

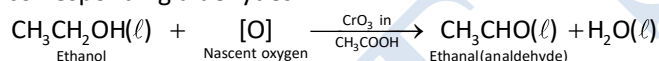

(ii) On oxidation with alkaline potassium permagnate (or acidified potassium dichromate), corresponding carboxylic acid is formed.

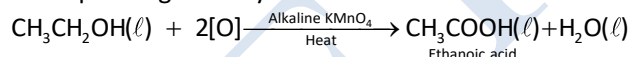

3. Addition reaction

Reactions in which unsaturated hydrocarbons (unsaturated carbon compounds) react with a molecule like H₂, X₂, H₂O etc. to form saturated compounds are called addition reactions.

Example : Unsaturated hydrocarbons add hydrogen, in the presence of catalysts, such as nickel or palladium to give saturated hydrocarbons.

(i) Addition of hydrogen to ethene : Hydrogenation reaction

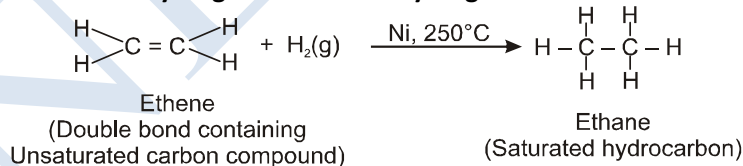

(ii) Addition of hydrogen to ethyne

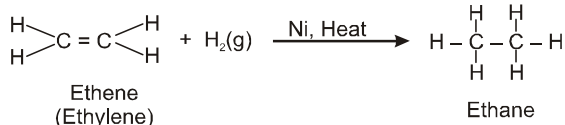
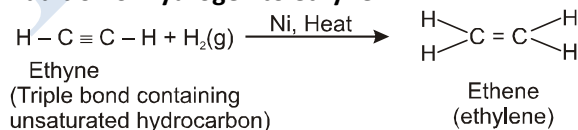

Addition of hydrogen to an unsaturated carbon compound is called hydrogenation reaction.

➤ **Chemical properties of ethanol -**

(i) **Combustion (or burning)** : Ethanol is highly inflammable liquid and readily burns in air with a blue flame to form water vapour, carbon dioxide and evolves heat. Thus, combustion of ethanol is an exothermic reaction.

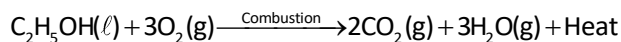

(ii) **Reaction with sodium metal** : Ethanol reacts with sodium metal to produce sodium ethoxide and hydrogen gas is evolved.

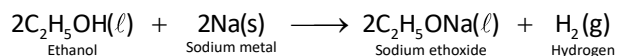

(iii) **Reaction with conc. sulphuric acid (Dehydration)** : Ethanol when heated with excess of concentrated sulphuric acid at 443 K, gets dehydrated to give ethene.

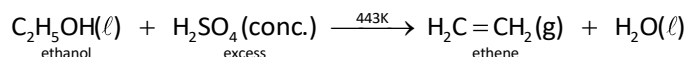

❖ **Note** : The concentrated sulphuric acid can be regarded as a dehydrating agent which removes water from ethanol.

➤ **Uses of ethanol**

- (i) Ethanol is present in alcoholic beverages such as beer, wine, whisky.
- (ii) As a solvent for paints, varnishes, dyes, cosmetics, perfumes, soaps and synthetic rubber etc.
- (iii) Ethanol is used in cough syrups, digestive syrups and tonics.
- (iv) A mixture of 80% petrol and 20% alcohol is called power alcohol. It is used as fuel in cars and aeroplanes.
- (v) A mixture of ethanol and water has lower freezing point than water this mixture is known as antifreeze and is used in radiators of vehicles in cold countries and at hill stations.
- (vi) As an antiseptic to sterilize wounds and syringes in hospitals.
- (vii) For the manufacture of terylene and polythene.
- (viii) As a preservative for biological specimens.
- (ix) Ethyl alcohol is used as hypnotic (induces-sleep).

2. Ethanoic acid (acetic acid) CH_3COOH

Ethanoic acid is commonly called acetic acid and belongs to the homologous series of carboxylic acid. Its chemical formula is CH_3COOH .

5-8% solution of acetic acid in water is called vinegar and is used for preserving foods like sausages, pickles, etc.

➤ **Physical properties**

- (i) At ordinary temperature, ethanoic acid is a colourless liquid with a strong pungent smell and sour taste.
- (ii) Its boiling point is 391 K and its density at 273 K is 1.08 (heavier than water).
- (iii) It is miscible with water due to the formation of hydrogen bonds with water molecules.
- (iv) On cooling at 289.6 K, it turns in ice-like crystals, hence named as glacial acetic acid.
- (v) It dissolves sulphur, iodine and many other organic compounds.
- (vi) It dimerises when dissolved in benzene.

➤ **Chemical properties of Ethanoic acid -**

(i) Reaction with alcohols (Esterification reaction)

Esters are sweet-smelling substances. These are used in making perfumes and as flavouring agents.

Ethanoic acid reacts with ethanol in the presence of conc. H_2SO_4 to form ethyl ethanoate which is an ester.

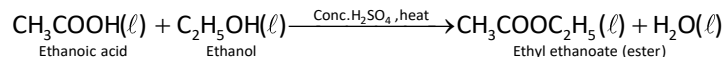

The reaction of carboxylic acid with an alcohol to form an ester is called “esterification reaction”.

Note : Ester can be hydrolysed in the presence of an acid or a base to give back the parent carboxylic acid and the alcohol.

Example

(a) Ethyl ethanoate on acid hydrolysis gives ethanoic acid and ethanol.

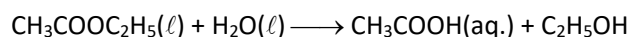

(b) Hydrolysis of ester in the presence of base (alkali) is called

“Saponification reactions”.

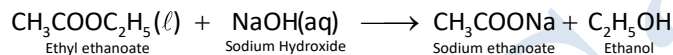

Note : Alkaline hydrolysis of higher esters is used in the manufacture of soaps.

(ii) Reaction with sodium carbonate and sodium hydrogen carbonate

Ethanoic acid decomposes sodium hydrogen carbonate and sodium carbonate with a rapid evolution of carbondioxide gas.

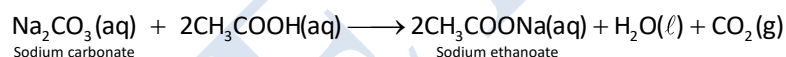
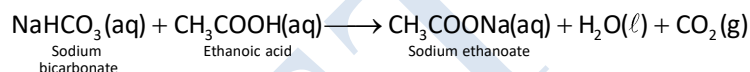

Note : Reaction of ethanoic acid with NaOH , NaHCO_3 , Na_2CO_3 and active metals show that the hydrogen present in the carboxyl ($-\text{COOH}$) group is acidic in nature.



Think Wise

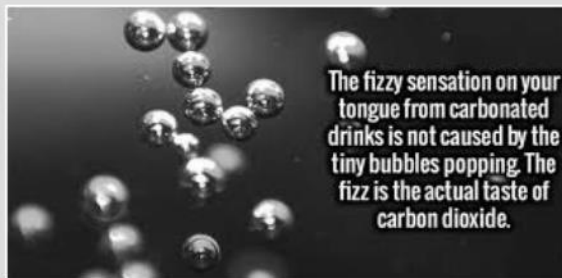

The fizzy sensation on your tongue from carbonated drinks is not caused by the tiny bubbles popping. The fizz is the actual taste of carbon dioxide.

➤ **Uses of ethanoic acid**

1. Ethanoic acid is used in the manufacture of various dyes, perfumes and rayon.
2. It is used for making vinegar.
3. Its 5% solution is bactericidal (destroys bacteria).
4. It is used for coagulation of the latex.

4.14 SOAPS AND DETERGENTS

Any substance which shows cleansing action in water is called a detergent. Detergents are of two types: soapy and non-soapy. Detergents with soapy touch are called soaps and detergents with non-soapy touch are called 'synthetic detergents' or just 'detergents'.

Soaps and detergents are used for washing clothes (laundry), sanitation, shaving creams and soaps, shampoos, cleaning utensils and in textiles.

➤ Soaps

Soaps are sodium salts (or potassium salts) of a long chain carboxylic acids (fatty acids) which have cleansing properties in water. Soap molecule contains a large non-ionic hydrocarbon chain (tail) and an ionic group, $\text{COO}^- \text{Na}^+$ (head). Some examples are : Sodium stearate and Sodium palmitate.

(i) **Sodium stearate, $\text{C}_{17}\text{H}_{35}\text{COO}^- \text{Na}^+$** : Sodium stearate is the sodium salt of a long chain saturated fatty acid called stearic acid, $\text{C}_{17}\text{H}_{35}\text{COOH}$. Sodium stearate soap has a long alkyl group $\text{C}_{17}\text{H}_{35}$ and an ionic carboxylate group $\text{COO}^- \text{Na}^+$.

(ii) **Sodium Palmitate, $\text{C}_{15}\text{H}_{31}\text{COO}^- \text{Na}^+$** : Sodium palmitate is the sodium salt of a long chain saturated fatty acid called palmitic acid, $\text{C}_{15}\text{H}_{31}\text{COOH}$.

Chemically soaps are salts of a strong base (like sodium hydroxide) and a weak acid (a carboxylic acid), therefore in aqueous solution they show basic nature and turn red litmus paper blue.

➤ Manufacture of Soap

Soaps are prepared by heating animal fat or vegetable oil with concentrated sodium hydroxide solution (caustic soda solution). When heated with sodium hydroxide solution, fats and oils (obtained from animals and plants) split to form sodium salt of higher fatty acids (called soap) and glycerol. The reaction is called saponification.

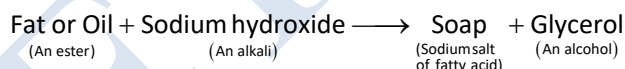

This process of making soap by the hydrolysis of fats and oils with alkali is called saponification

During saponification, common salt is added to the mixture to precipitate out all the soap from the aqueous solution as it is more soluble in water as compared to soap. In absence of common salt some soap remain dissolved in mixture which is not precipitated on heating.

Activity 1 :

To study the formation of soap

- **Materials required** : Beakers, 20 mL of castor oil or linseed oil or soyabean oil and 30 mL of 20% sodium hydroxide solution.
- **Procedure** :
 - Take about 20 mL of castor oil (or linseed oil or soyabean oil) in a beaker and add to it 30 mL of 20% sodium hydroxide solution.
 - Heat the mixture with continuous stirring for a few minutes.
 - The oil and water layers merge with each other and the resulting mixture becomes thick.
 - Add 5-10 g of common salt to it, stir the mixture and allow it to cool.

- **Observations** : A pale yellow solid cake is formed. It is known as soap.
- **Conclusion** : The same principle is used for making soaps in the soap industry. Some other additions like perfumes, disinfectants and medicines are added to soap to give it the desired characteristics.
- **Structure and Cleansing Action of Soap**
A soap molecule is made up of two parts : A long hydrocarbon part (tail) and a short ionic part (head) containing $\text{-COO}^- \text{Na}^+$ group. The soap molecule is said to have a tadpole structure.

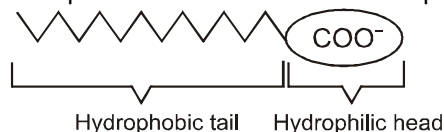

The long hydrocarbon chain is hydrophobic (water-repelling) and is insoluble in water but soluble in oil and grease. The ionic portion of the soap molecule is hydrophilic (water - attracting) due to the polar nature of water molecules and is soluble in water but insoluble in oil and grease.

Hydrocarbon part of the soap molecule is soluble in oil or grease thus attach with oil and grease particles the water particles (in which the soap is dissolved and dirty cloth is dipped). This way soap molecules form spherical micelles in which hydrophobic chains are projected inwards and hydrophilic heads are projected outwards.

A 'spherical aggregate of soap molecule' in the soap solution in water called a 'micelle'

When dissolve in water, soap molecules ionise and Na^+ ions are removed from head. Due to this reason, overall charge on surface of micelles is negative. Due to negative charge on outer surface micelles repel each other and stabilize to produce a colloidal solution.

Thus, when we agitate a dirty soap solution, the oily and greasy particles present on cloth surface are entrapped by soap micelles which get dispersed in water. This results in dirty appearance of soap solution. Micelles attach to cloth (suspended in water present in cloth) are removed by rinsing cloth in clean water a number of times. A soap solution appears cloudy because the soap micelles are larger enough to scatter light.

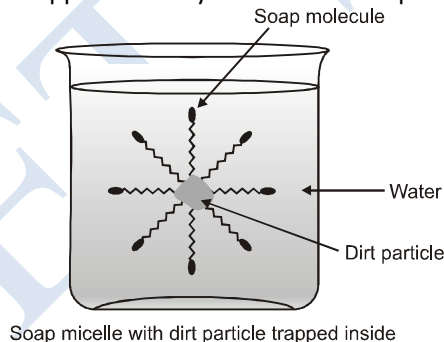

When soap is dissolved in organic solvents like ethanol or chloroform micelles are not formed because long hydrocarbon chain is soluble in organic solvents.

- **Limitations of Soap**

Major limitation of soap is that it is not suitable for washing clothes with hard water. It is because of two reasons :

- Soap does not give lather easily with hard water as a large amount of soap is wasted in reacting with ions present in hard water to form an insoluble curdy precipitate called scum, before it is used for washing. In hard water soap first reacts with the calcium or magnesium ions present in hard water to form insoluble precipitates of calcium or magnesium salts of fatty acids (scum). This increases the amount of soap required for washing clothes.
- The scum formed, sticks to the clothes and interferes with the cleansing ability of soap. This makes the cleaning of clothes difficult.
- The formation of lather or foam (jhaag) is necessary for removing dirt from clothes during the washing of clothes. Soft water, however, does not contain any calcium ions or magnesium ions and, therefore, lathers easily when soap is added.

➤ **DETERGENTS**

Detergents are also called 'soap-less soaps' because though they act like a soap in having the cleansing properties, they do not have usual soapy touch of 'soaps' like sodium stearate, etc. They are better cleansing agents because they do not give insoluble calcium or magnesium salts with hard water, and therefore can be used for washing even with hard water.

A detergent is the sodium salt of a long chain benzenesulphonic acid for for the sodium salt of a long chain alkyl hydrogensulphate which has cleansing properties in water.

A detergent has a large non-ionic hydrocarbon group and an ionic group like sulphonate group, $\text{SO}_3^- \text{Na}^+$, or sulphate group $\text{SO}_4^- \text{Na}^+$. Examples of detergents are : sodium n-dodecylbenzene sulphonate and sodium n-dodecylsulphate. These are shown below :



The structure and cleansing action of a detergent is similar to that of soaps. A detergent molecule also consists of two parts : a long hydrocarbon chain which is water-repelling (hydrophobic), and a short ionic part which is water-attracting (hydrophilic). Detergents are prepared from long chain hydrocarbons obtained during refining of petroleum oil. They are generally used to make washing powders and shampoos.

Major Differences between Soaps and Detergents

| | Soaps | Detergents |
|---|---|---|
| 1 | Soaps are the sodium salts (or potassium salts) of the long chain carboxylic acids (fatty acids) The ionic group in soaps is $-\text{COO}^- \text{Na}^+$. | Detergents are the sodium salts of long chain benzenesulphonic acids or long chain alkyl hydrogensulphates. The ionic group in a detergents is $-\text{SO}_3^- \text{Na}^+$ or $-\text{SO}_4^- \text{Na}^+$ |
| 2 | Soaps are not suitable for washing with hard water as they form scum. | Detergents can be used for washing even with hard water. |
| 3 | Soaps are biodegradable. | Some of the detergents are non-biodegradable. |
| 4 | Soaps have relatively weak cleansing action. | Detergents have a strong cleansing action. |

• **Advantages of detergents over soaps**

Detergents have a number of advantages over soaps as washing agents :

- (i) Detergents can be used even with hard water.
- (ii) Detergents have a stronger cleansing action.
- (iii) Detergents are more soluble in water.

• **Disadvantages of detergents over soaps**

Major disadvantage of detergents over soaps is that many detergents are not biodegradable and cannot be decomposed by micro-organisms like bacteria and thus cause water pollution in lakes and rivers. All the soaps are, however, biodegradable.

Activity 2 :

To illustrate that soap does not work in hard water.

- **Materials required :** Distilled water, rain water, hard water (from tube well or hand pump), test tubes and soap solution.
- **Procedure :**
 - Take about 10 mL of distilled water (or rain water) and 10 mL of hard water (from tube well or hand pump) in separate test tubes.
 - Add 4-5 drops of soap solution to both.
 - Shake the test tubes vigorously for an equal period of time and observe the amount of foam formed.
- **Observations :** More foam is formed in the test tube containing distilled water than the test tube containing hard water.
- **Conclusion :** White curdy precipitate is formed in test tube containing hard water.

➤ **Some illustrations based on soaps and detergents**

Illustration 1 : Show an activity to prove detergents are more effective in hard water than soaps.

Ans. To prove detergents are more effective in hard water than soaps.

Procedure :

- Add five drops of soap solution to one and five drops of detergents solution to the other.
- Shake both test tubes for the same period.

Observations : Test tube containing soap solution gives less foam than the test tube containing detergent solution.

A curdy white solid is formed in the test tube to which soap solution was added.

Illustration 2 : Write main properties of synthetic detergents.

Ans. Synthetic detergents do not react with the ions present in hard water. Hence, synthetic detergents have no problem in forming lather with hard water, i.e. their efficiency is not affected by hard water. They even lather in sea water and water containing acids. Apart from this, synthetic detergents dissolve faster than soaps in water. That is why, they have almost replaced soap in the cleansing of clothes.

Illustration 3 : Explain cleansing action of soap with the help of the structure of soap.

Ans. A soap molecule contains two chemically distinct parts that interact differently with water. One part is a long hydrocarbon chain, and the other belongs to the $-\text{COONa}$ group. The hydrocarbon chain is non-polar and water-hating (hydrophobic), while the other part (charged carboxylate group $-\overset{\text{O}}{\parallel}{\text{C}}-\text{O}^-$)

belonging to the $-\text{COONa}$ group, is polar and water-loving (hydrophilic). The hydrophilic part makes the soap soluble in water. So, a soap molecule can be thought of as one having a long tail made of hydrogen and carbon molecules and a short head made of C, O and Na. The long tail is dirt-loving and water-hating and the short head is water-loving.

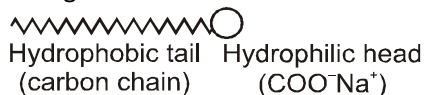

When soap is added to water, the soap molecules assume a configuration which increases the interaction of the water-loving heads with the water molecules, and decreases the interaction between the water-hating tails with the water molecules. The water-hating, non-polar tails clump together in a radial fashion with the water-loving, polar heads remaining at the periphery of the clump. These clumps or droplets of soap molecules are called micelles. The dirt thus enveloped in the non-polar part.

Illustration 4 : Why is cleansing action of detergents considered more effective than soaps ?

Ans. The cleansing action of detergents is considered to be more effective than a soap. This is because a detergent does not give precipitate with metal ions such as Ca^{2+} or Mg^{2+} , which are responsible for hardness of water. On the other hand, soap forms precipitate (called scum) with these ions, and is thus, thrown out of solution. Therefore, soaps are not effective cleansing agents in hard water.

➤ **Chloro - Fluoro Carbon or Freons :**

"Poly chloro - fluoro alkanes are called freons". When chlorine and fluorine on combination with carbon atom form a compound, then such a compound is called chloro - fluoro carbon (CFC), which is also called freon.

➤ **Preparation of Freon :**

Freon - 11 is obtained by the reaction of carbon tetrachloride (CCl₄) and hydrogen fluoride (HF) in the presence of SbCl₅.

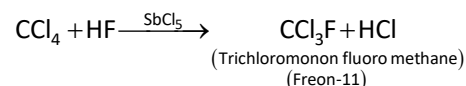

➤ **Nomenclature of Freon**

The nomenclature of Freon is based on number of carbon, hydrogen and fluorine atoms present in the molecular formula of Freon. e.g., Freon - XYZ

Where X = Number of carbon atoms in Freon molecule - 1, i.e. (C-1)

Y = Number of hydrogen atoms present in Freon molecule + 1, i.e. (H + 1)

Z = Number of fluorine atoms present in Freon molecule.

| Nomenclature of Main Freons | | | | |
|---|---|---|---|---------------|
| Molecular formula | X | Y | Z | Name of Freon |
| CFCl ₃ | 0 | 1 | 1 | Freon-11 |
| CF ₂ Cl ₂ | 0 | 1 | 2 | Freon - 12 |
| C ₂ F ₂ Cl ₄ | 0 | 1 | 2 | Freon - 12 |
| C ₂ F ₂ Cl ₄ | 1 | 1 | 2 | Freon - 112 |
| C ₂ F ₃ Cl ₃ | 1 | 1 | 3 | Freon - 113 |

Uses of Freons :

1. Used in the form of inert solvent.
2. Used as a coolant in refrigerators, air - conditioners and cold storage.

➤ **Compressed natural Gas (CNG)**

Compressed natural gas is called CNG. It contains mainly methane and some other hydrocarbons. The percentage of carbon in CNG is less, so less amount of carbon monoxide (CO) and carbon dioxide (CO₂) is produced by its combustion. So, it is less harmful than petroleum products for the environment.

The gas found in the upper layer of petroleum in depth of the earth is called natural gas. Natural gases are also obtained during mining of petroleum. When natural gas is compressed at high temperature then it is called compressed natural gas.

CNG gas differs from LPG. On fractional distillation of petroleum, the gases obtained with different components of petroleum, are called petroleum gases. These gases can be converted into liquid by compressing them at high pressure. Then, it is called LPG (Liquid Petroleum Gas).

CNG is more safe gas than LPG because CNG is lighter than LPG, due to which it spreads rapidly in air on leakage. On the other hand, LPG is accumulated the lower surface due to its more density.

• **Uses of CNG**

1. Used as fuel.
2. Now a days CNG is used in place of petrol and diesel as a fuel in various vehicles and in modern means of transportation.

POLYMER

OUTLINE :

- Introduction
- Classification of Polymers

- Properties of Polymers
- Polymers and their Monomers
- Polymerization Reactions
- Uses of Polymers
- Commercial use of Polymers
- Summary of some common polymers, their synthesis, along with structures

Introduction : A polymer is a large molecule or a macromolecule which essentially is a combination of many subunits. The term polymer in Greek means 'many parts'. Polymers can be found all around us. From the strand of our DNA which is a naturally occurring biopolymer to polypropylene which is used throughout the world as plastic.

Polymers may be naturally found in plants and animals (natural polymers) or may be man-made (synthetic polymers). Different polymers have a number of unique physical and chemical properties due to which they find usage in everyday life.

Polymers are all created by the process of polymerization wherein their constituent elements called monomers, are reacted together to form polymer chains i.e 3-dimensional networks forming the polymer bonds.

The type of polymerization mechanism used depends on the type of functional groups attached to the reactants. In biological contexts, almost all macromolecules are either completely polymeric or are made up of large polymeric chains.

CLASSIFICATION OF POLYMERS

Polymers cannot be classified under one category because of their complex structures, different behaviours, and vast applications. We can, therefore, classify polymers based on the following considerations.

(1) Classification of Polymers based on the Source of Availability

There are three types of classification under this category, namely, Natural, Synthetic, and Semi-synthetic Polymers.

(i) Natural Polymers:

They occur naturally and are found in plants and animals. For example proteins, starch, cellulose, and rubber. To add up, we also have biodegradable polymers which are called biopolymers.

Natural Rubber : This is obtained from a tree in the form of liquid which is called Latex. Natural rubber is a polymer of isoprene.

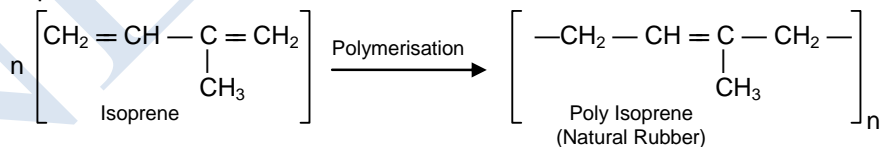

Latex is converted into solid by adding acetic acid. The rubber so obtained has low elasticity and low tensile strength. It is heated with sulphur for increasing its elasticity and tensile strength. This process is called vulcanization. The rubber so obtained is less resistant to abrasion, rigid, hard and more elastic.



Think Wise

Natural rubber is highly elastic to be of poor physical stability. Addition of 5% of sulphur, enhances the crosslinking of the linear chains and thus improves the stiffening of the rubber for an application like vehicle tires

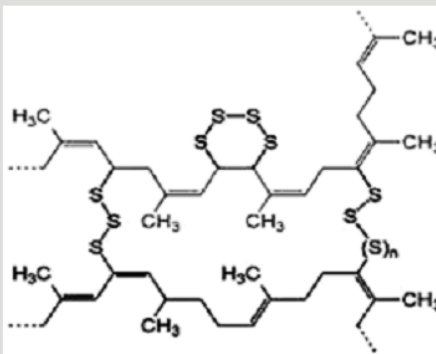

Cross linking during vulcanization makes the Rubber more rugged.

(ii) Semi-synthetic Polymers:

They are derived from naturally occurring polymers and undergo further chemical modification. For example, cellulose nitrate, cellulose acetate.

Rayon

Paper (Cellulose) is cleaned by pouring it in solution carbon disulphide of sodium hydroxide then the solution of cellulose is obtained by dissolving it in carbon disulphide (CS₂). This solution is sprayed in dilute sulphuric acid by passing it through fine pores, by which fine shiny fibres of rayon are formed.

Uses : Used in making clothes, threads, carpets, etc.

(iii) Synthetic Polymers:

These are man-made polymers. Plastic is the most common and widely used synthetic polymer. It is used in industries and various dairy products. For example, nylon-6, 6, polyether's, Polyacrylonitrile or Polycyanide etc.



Nylon fibre has high tensile strength

Polyacrylonitrile or Orlon

It is obtained by the polymerization of vinyl cyanide.



(2) Classification of Polymers based on the Structure of the Monomer Chain

This category has the following classifications:

(i) Linear Polymers

The structure of polymers containing long and straight chains fall into this category. PVC, i.e. poly-vinyl chloride is largely used for making pipes and electric cables is an example of a linear polymer.

(ii) Branched-chain Polymers

When linear chains of a polymer form branches, then, such polymers are categorized as branched chain polymers. For example, Low-density polythene. (LDPE)

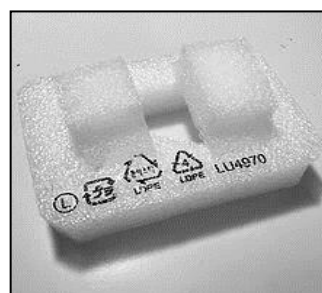

LDPE

(iii) Cross-linked Polymers

They are composed of bifunctional and trifunctional monomers. They have a stronger covalent bond in comparison to other linear polymers. Bakelite, melamine, HDPE etc are examples in this category.

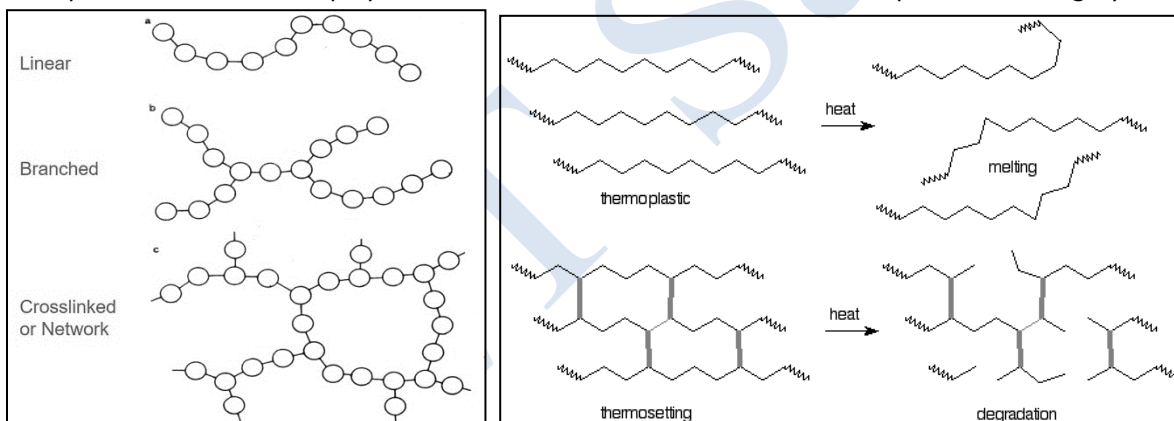

Bakelite, the world's **first fully synthetic plastic**, was invented on Feb 5, 1907

'A MATERIAL OF THOUSAND USES'

Was **invented by** Belgian-born American chemist **Leo Hendrik Baekeland**

It kick-started the **modern plastics industry**

Because it was **durable, lightweight & easily mouldable** it revolutionised the consumer durables industry

It was useful in **automotives & electrical industries** also

Bakelite's biggest influence was on perhaps the fashion industry—making jewellery attractive & cheap

Some information on Bakelite



HDPE Pipes



Bangles made of Bakelite

(3) Classification Based on Polymerization

(i) Addition Polymerization:

This is also called as chain growth polymerization. In this, small monomer units joined to form a giant polymer. In each step, length of chain increases. For example, Polymerization of ethene in the presence of Peroxides Example, polyethene, Teflon, Polyvinyl chloride (PVC)

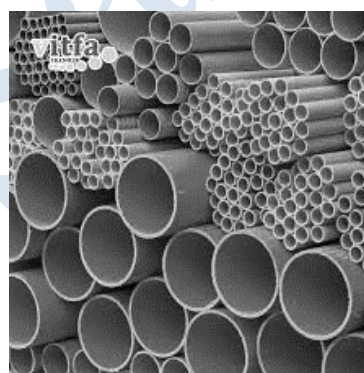

PVC Pipes

(ii) Condensation Polymerization:

In this type small molecules like H_2O , CO , NH_3 are eliminated during polymerization (step growth polymerization). Generally, organic compounds containing bifunctional groups such as diols, -dials, diamines, dicarboxylic acids undergo this type of polymerization reaction. For example, Preparation of nylon -6, 6. Example, Nylon -6, 6, perylene, polyesters.

(4) Classification Based on Monomers

- (i) Homomer: In this type, a single type of monomer unit is present. For example, Polyethene
- (ii) Heteropolymer or co-polymer: It consists of different type of monomer units. For example, nylon -6, 6

(5) Classification Based on Molecular Forces

- (i) Elastomers: These are rubber-like solids weak interaction forces are present. For example, Rubber.
- (ii) Fibres: Strong, tough, high tensile strength and strong forces of interaction are present. For example, nylon -6, 6.
- (iii) Thermoplastics: These have intermediate forces of attraction. For example, polyvinyl chloride, Polyethylene, Polypropylene etc.

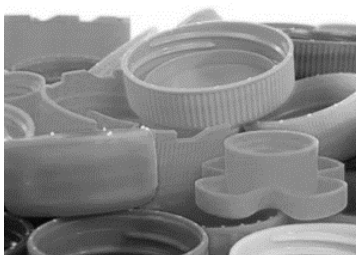

Polypropylene use

(iv) Thermosetting polymers: These polymers greatly improve the material's mechanical properties. It provides enhanced chemical and heat resistance. For example, phenolics, epoxies, and silicones.

(6) Classification based on the backbone chain

(i) **Organic Polymers** : Most of the polymers around us are made up of a hydrocarbon backbone. A Hydrocarbon backbone being a long chain of linked carbon and hydrogen atoms, possible due to the tetravalent nature of carbon.

A few examples of a hydrocarbon backbone polymer are polypropylene, polybutylene, polystyrene.

(ii) **Inorganic Polymers**: Also, there are polymers which instead of carbon have other elements in its backbone. For example, Nylon, which contains nitrogen atoms in the repeated unit backbone.

DIFFERENT TYPES OF POLYMERS

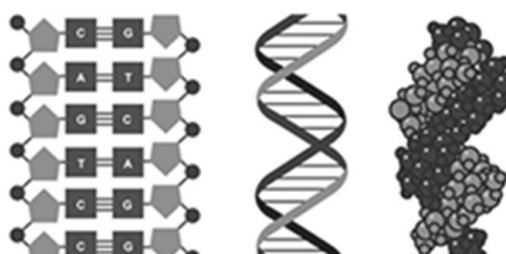

NATURAL POLYMERS



SYNTHETIC POLYMERS

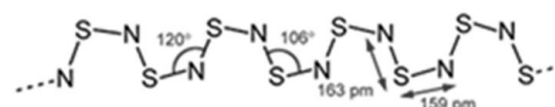

INORGANIC POLYMERS

$$\begin{array}{ccccccc}
 \text{Cl} & \text{H} & \text{Cl} & \text{H} & \text{Cl} & \text{H} & \\
 | & | & | & | & | & | & \\
 \text{---C---C---C---C---C---C---} & & & & & & \\
 | & | & | & | & | & | & \\
 \text{H} & \text{H} & \text{H} & \text{H} & \text{H} & \text{H} &
 \end{array}$$

ORGANIC POLYMERS

Think Wise

Biodegradable Polymers :The polymers which are degraded and decayed by microorganisms like bacteria are known as biodegradable polymers. These types of polymers are used in surgical bandages, capsule coatings and in surgery. For example, Poly hydroxybutyrate co velerate [PHBV]

CHEMISTRY

➤ PROPERTIES OF POLYMERS

Physical Properties

- (i) As chain length and cross-linking increases the tensile strength of the polymer increases.
- (ii) Polymers do not melt, they change state from crystalline to semi-crystalline.

Chemical Properties

- (i) Compared to conventional molecules with different side molecules, the polymer is enabled with hydrogen bonding and ionic bonding resulting in better cross-linking strength.
- (ii) Dipole-dipole bonding side chains enable the polymer for high flexibility.
- (iii) Polymers with Van der Waals forces linking chains are known to be weak, but give the polymer a low melting point.

Some Polymers and their Monomers

- Polystyrene

It is obtained by the polymerization of vinyl benzene (styrene)

Uses : Used in making tea cups bottle caps, refrigerator parts, wall tiles, packing materials, etc.

 Think Wise

Glyptal is made up of monomers ethylene glycol and phthalic acid

 Think Wise

What is Copolymerization?
In this process, two different monomers joined to form a polymer. Synthetic rubbers are prepared by this polymerization. For example, BUNA – S

➤ USES OF POLYMERS

Some of the important uses of polymers in our everyday life are :

- (i) Polypropene finds usage in a broad range of industries such as textiles, packaging, stationery, plastics, aircraft, construction, rope, toys, etc.
- (ii) Polystyrene is one of the most common plastic, actively used in the packaging industry. Bottles, toys, containers, trays, disposable glasses and plates, tv cabinets and lids are some of the daily-used products made up of polystyrene. It is also used as an insulator.



Polystyrene

- (iii) The most important use of polyvinyl chloride is the manufacture of sewage pipes. It is also used as an insulator in the electric cables.
- (iv) Polyvinyl chloride is used in clothing and furniture and has recently become popular for the construction of doors and windows as well. It is also used in vinyl flooring.

- (v) Urea-formaldehyde resins are used for making adhesives, moulds, laminated sheets, unbreakable containers, etc.
- (vi) Glyptal is used for making paints, coatings, and lacquers.
- (vii) Bakelite is used for making electrical switches, kitchen products, toys, jewellery, firearms, insulators, computer discs, etc.

➤ **Commercial Uses of Polymers**

| Polymer | Monomer | Uses of Polymer |
|-----------------------------|---|---------------------------------|
| Rubber | Isoprene (1, 2-methyl 1 – 1, 3 butadiene) | Making tyres, elastic materials |
| BUNA – S | (a) 1, 3-butadiene (b) Styrene | Synthetic rubber |
| BUNA – N | (a) 1, 3-butadiene (b) Vinyl Cyanide | Synthetic rubber |
| Teflon | Tetra Fluoro Ethene | Non-stick cookware – plastics |
| Terylene | (a) Ethylene glycol (b) Terephthalic acid | Fabric |
| Glyptal | (a) Ethylene glycol (b) Phthalic acid | Fabric |
| Bakelite | (a) Phenol (b) Formaldehyde | Plastic switches, Mugs, buckets |
| PVC | Vinyl Cyanide | Tubes, Pipes |
| Melamine Formaldehyde Resin | (a) Melamine (b) Formaldehyde | Ceramic plastic material |
| Nylon-6 | Caprolactum | Fabric |

SUMMARY OF SOME COMMON POLYMERS, THEIR SYNTHESIS, ALONG WITH STRUCTURES :

(1) Terylene (a synthetic fibre)

- (i) It is synthesized by condensation polymerization of ethylene glycol and terephthalic acid. It is also known as Dacron.

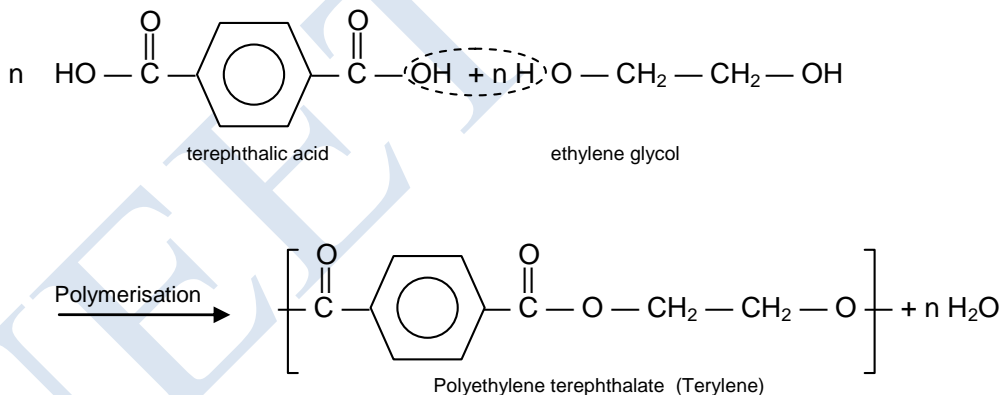

Uses : Used in making clothes, sail of boats, belt, magnetic tape, film, etc.

(2) Buna - S

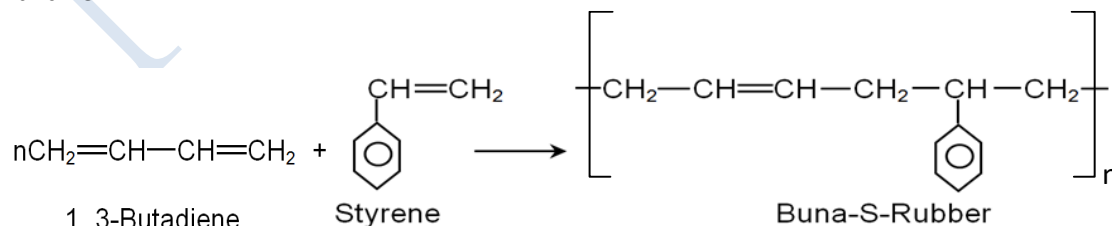

Uses : It is extensively used in coated papers, being one of the most cost-effective resins to bind pigmented coatings. It is also used in building applications, as a sealing and binding agent behind renders as an alternative to PVA. Additionally, it is used in some rubber cutting boards.

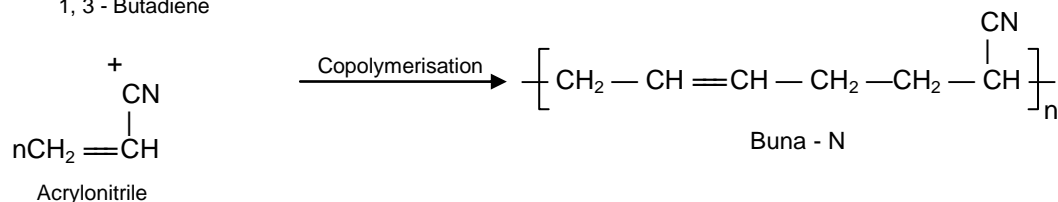
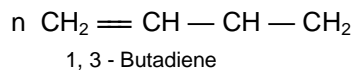
CHEMISTRY
(3) Buna - N

Uses : Used in making oil tanks, tyre-tubes, medical equipments, petrol taps, shoe soles, etc. It is used in preparation of adhesives and as a pigment binder. It is also use for hoses, rubber belts, sealing parts, rubber seal, gaskets, shoe soles etc.

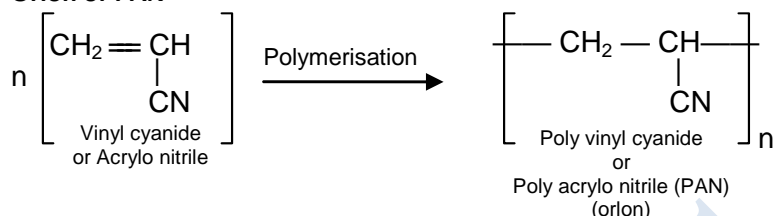
(4) Orlon or PAN

Use : Fibers of polyacrylonitrile have been used in hot gas filtration systems, outdoor awnings, sails for yachts, and even fiber reinforced concrete. But mostly copolymers containing polyacrylonitrile are used as fibers to make knitted clothing like socks and sweaters, as well as outdoor products like tents.

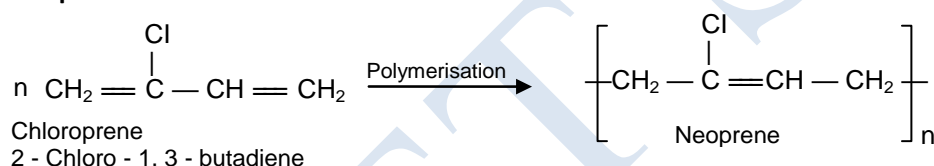
(5) Neoprene

Uses : Is a popular material in making protective clothing for aquatic activities. Foamed neoprene is commonly used to make fly fishing waders and wetsuits, as it provides excellent insulation against cold.

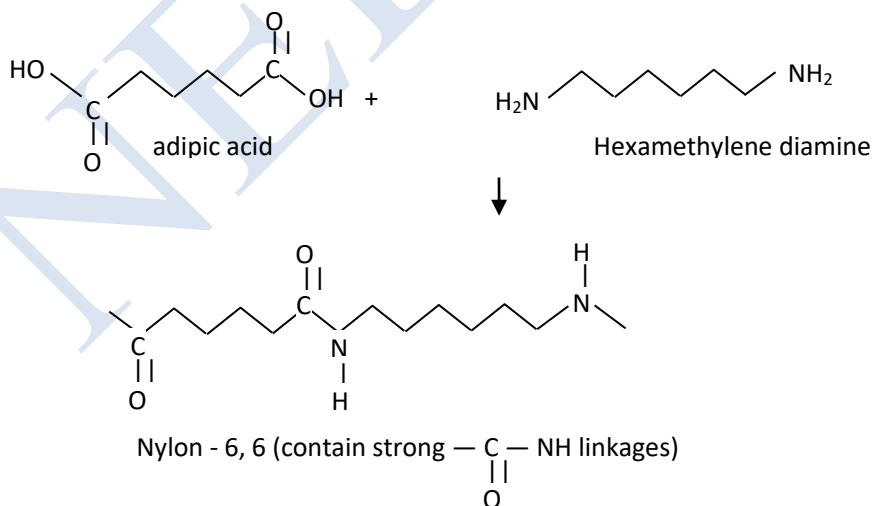
(6) Nylon - 6, 6 preparation

Uses : Nylon is used for a variety of applications to include clothing, reinforcement in rubber material like car tires, for use as a rope or thread, and for a number of injection molded parts for vehicles and mechanical equipment

(7) Bakelite Preparation

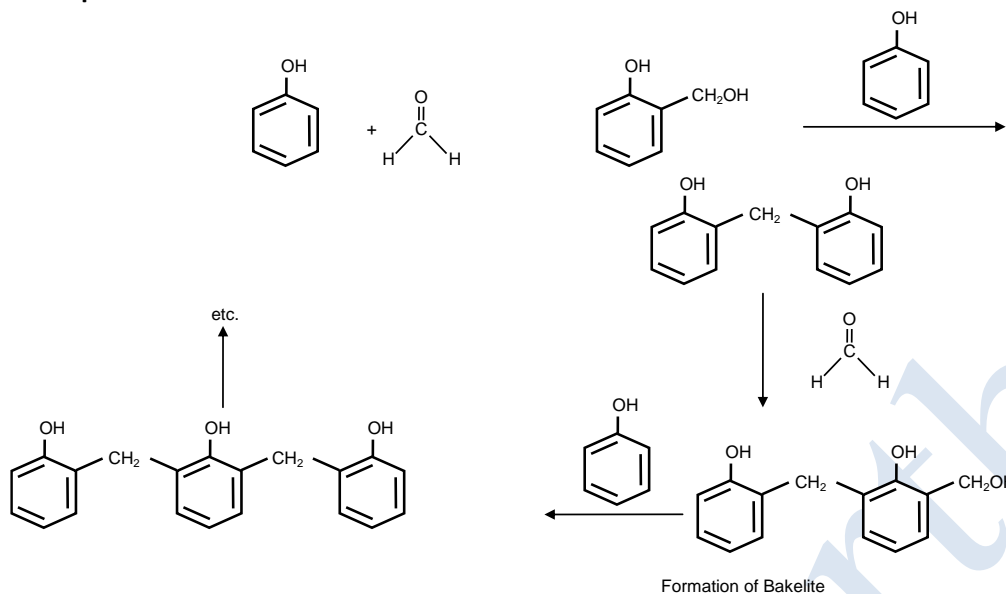

Uses :

- Bakelite due to its high resistance to electricity and heat is used in automotive components and industrial applications.
- Due to excellent insulating properties it is used for making switches and other electrical appliances.
- It is also used to make various kitchenware products like frying pans etc.

(8) Polythene Synthesis

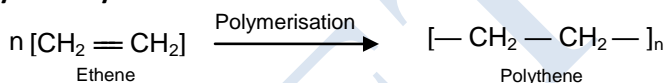

Uses : Its primary use is in packaging (plastic bags, plastic films, geomembranes, containers including bottles, etc.) Many kinds of polyethylene are known, with most having the chemical formula $(\text{C}_2\text{H}_4)_n$. PE is usually a mixture of similar polymers of ethylene with various values of n .

(9) Polystyrene :

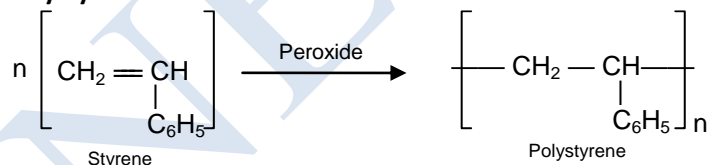

(10) PVC :



Uses : PVC is used in variety of applications in the building and construction, health care, electronics, automobile and other sectors, in products ranging from piping and siding, blood bags and tubing, to wire and cable insulation.

NCERT QUESTIONS WITH SOLUTIONS

Q.1 What would be the electron dot structure of carbon dioxide which has the formula CO_2 ?

Ans. The atomic number (Z) for carbon is six and its electronic configuration is 2, 4. Carbon has four valence electrons. Each oxygen atom (Z = 8) has six valence electrons (2, 6). In order to complete its octet, the carbon atom shares its four valence electrons with the four electrons of the two oxygen atoms as follows :

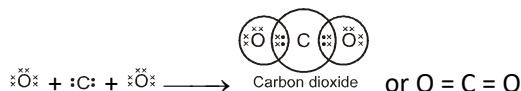

Thus, in carbon dioxide molecule, the carbon atom is linked to two oxygen atoms on both sides by two shared pairs of electrons resulting in double bonds on either sides. Both carbon and oxygen atoms complete their octet as a result of electron sharing.

Q.2 What would be the electron dot structure of a molecule of sulphur which is made up of eight atoms of sulphur ? (Hint : The eight atoms of sulphur are joined together in the form of a ring).

Ans. The atomic number (Z) of sulphur is sixteen and its electronic configuration is 2, 8, 6. The sulphur atom has six valence electrons. The chemical formula of sulphur molecule is S_8 . Each sulphur atom is linked to similar atoms on either sides by single covalent bonds and thus, completes its octet. The molecule is in the form of a ring also represented by crown shape.

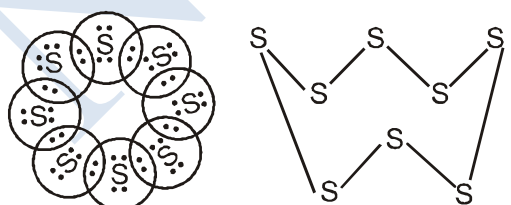

Ring structure of S_8 molecule Crown shape of S_8 molecule

Q.3 How many structural isomers can you draw for pentane ?

Ans. Pentane (C_5H_{12}) has a skeleton of five carbon atoms. It can exist as a straight chain as well as two branched chains. There are three structural isomers for the hydrocarbon which is an alkane.

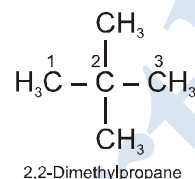
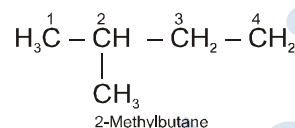
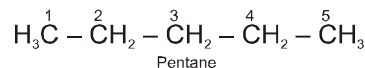

Q.4 What are the two properties of carbon which lead to the huge number of carbon compounds we see around us ?

Ans. (i) Catenation : Carbon has the unique property of self linking which is known as catenation. In fact, any number of carbon atoms can be linked to one another by covalent bonds. This is on account of the stability of C – C bonds since the size of the carbon atom is quite small.
 (ii) Linking of carbon with other atoms : Carbon is tetravalent in nature and can readily unite with atoms like hydrogen, oxygen, nitrogen, sulphur etc. by electron sharing.

Q.5 What will be the formula and electron dot structure of cyclopentane ?

Ans. Cyclopentane is a cyclic compound with formula C_5H_{10} . The structure of the compound may be represented as :

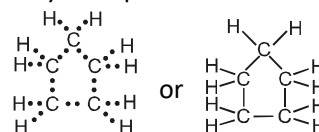

Q.6 Draw the structures of the following compounds:

- (i) Ethanoic acid (ii) Bromopentane
 (iii) Butanone (iv) Hexanal

Are structural isomers possible for bromopentane?

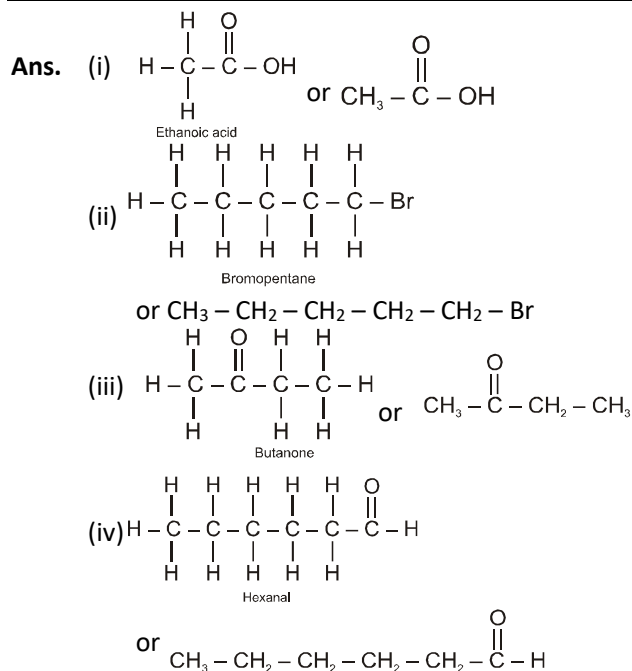

Bromopentane has a chain of five carbon atoms. It can exist in a number of forms which are structural isomers.

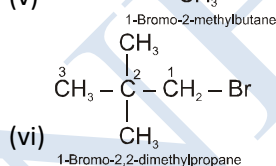
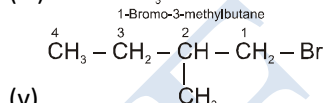
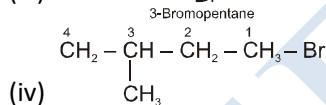
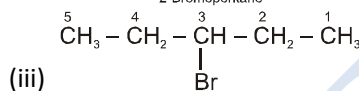
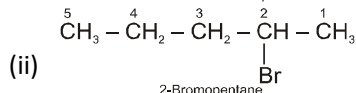
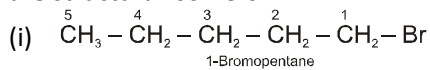

- The structural isomers (i), (ii) and (iii) which differ in the position of the Br atom are known as position isomers.
- The structural isomers (iv), (v) and (vi) which differ in the arrangement of carbon atoms in the chain are called chain isomers.
- In writing the IUPAC name, the name of prefix bromo is written before that of prefix methyl. In fact, alphabetical order is followed while naming the different prefixes.

Q.7 How would you name the following compounds ?

Ans. (i) $\text{CH}_3-\text{CH}_2-\text{Br}$

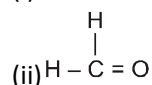

(iii) $\text{CH}_3-\text{CH}_2-\text{CH}_2-\text{CH}_2-\text{C}\equiv\text{C}-\text{H}$

Ans. (i) Bromoethane (ii) Methanal

(iii) Hex-1-yne

Q.8 Why is the conversion of ethanol to ethanoic acid an oxidation reaction ?

Ans. Ethanoic acid (CH_3COOH) have one oxygen atom more and two hydrogen atoms less than ethanol ($\text{C}_2\text{H}_5\text{OH}$). In general

Q Loss of hydrogen is known as oxidation.

- Gain of oxygen is known as oxidation.

Therefore, it is an oxidation reaction.

Q.9 A mixture of ethyne and oxygen is burnt for welding. Can you tell why a mixture of ethyne and air is not used ?

Ans. When ethyne is burnt in oxygen, large quantity of heat along with light is produced. The heat evolved can be used for gas welding which usually carried to weld small broken pieces of articles made up of iron.

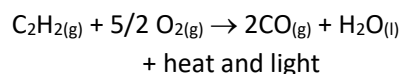

Air mainly contains a mixture of nitrogen (4 parts) and oxygen (1 part). As we known, nitrogen gas does not support combustion, this means that in air, only oxygen will help in the combustion of ethyne.

Q.10 How would you distinguish experimentally between an alcohol and a carboxylic acid ?

Ans. The distinction can be made by the following tests:

- Dip a strip of blue litmus separately in both alcohol and carboxylic acid taken in two glass tubes. The colour will change to red in the tube containing carboxylic acid and not in the tube which contains alcohol.
- Add a small amount of solid sodium hydrogencarbonate (NaHCO_3) in both the tubes. A brisk effervescence accompanied by bubbles will be noticed in the tube containing carboxylic acid and not in the tube containing alcohol.

CHEMISTRY

Q.11 What are oxidising agents ?

Ans. Oxidising agents are the substances which either on their own or on reacting with another substance release oxygen in order to carry oxidation reactions. The commonly used oxidising agents are ozone, bromine water, a mixture of potassium dichromate and sulphuric acid etc.

Q.12 Would you be able to check if water is hard by using a detergent ?

Ans. No, it is not possible. Actually detergents produce foam in any type of water; whether hard or soft. Therefore, a distinction between the two cannot be made. However, soaps can be used for this purpose.

Q.13 People use a variety of methods to wash clothes. Usually after adding the soap, they beat the clothes on a stone or beat them with a paddle, scrub with a brush or the mixture is agitated in a washing machine. Why is this agitation necessary to get clean clothes ?

Ans. The purpose of soap or detergent in washing is to reduce friction between oil drops carrying dirt particles and water so that they may mix with each other. All the methods that have been suggested loosen the bonds between the dust or oil particles and fabrics of clothes. The agitation helps in washing the clothes.

Q.14 Ethane, with the molecular formula C_2H_6 has
(i) 6 covalent bonds (ii) 7 covalent bonds
(iii) 8 covalent bonds (iv) 9 covalent bonds

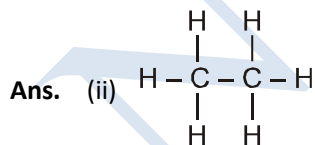

The molecule has seven covalent bonds.

Q.15 Butanone is a four carbon compound with the functional group

- (i) carboxylic acid (ii) aldehyde
(iii) ketone (iv) alcohol

Ans. (iii) The functional group is ketone ($>C=O$) also known as alkanone.

Q.16 While cooking, if the bottom of the vessel is getting blackened on the outside, it means that
(1) the food is not cooked completely
(2) the fuel is not burning completely
(3) the fuel is wet
(4) the fuel is burning completely

Ans. (2) The fuel is not burning completely. The unburnt particles present in smoke blacken the vessel from outside.

Q.17 Explain the nature of the covalent bond using the bond formation in CH_3Cl .

Ans. The molecule of chloromethane (CH_3Cl) consists of three elements i.e., carbon ($Z = 6$) hydrogen ($Z = 1$) and chlorine ($Z = 17$). Carbon atom has four valence electrons (2,4); hydrogen has one (1) while chlorine has seven electrons in the valence shell (2,8,7). In order to complete its octet, carbon shares three valence electrons with three hydrogen atoms while one is shared with the electron of chlorine atom. The structure of covalent molecule may be written as follows :

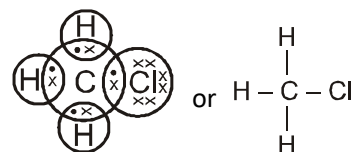

Q.18 Draw the electron dot structures for

- (i) Ethanoic acid (ii) H_2S
(iii) Propanone (iv) F_2

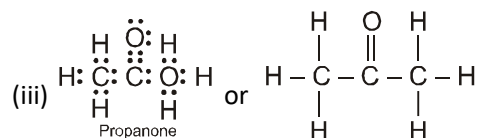
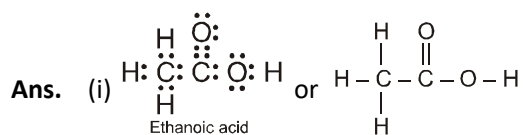

Q.19 What is a homologous series ? Explain with an example.

Ans. A homologous series can be defined as a family of organic compounds having the same functional group, similar chemical properties and the successive members of which differ by a $-\text{CH}_2$ group of 14 mass units. For example, CH_3OH (methanol), $\text{CH}_3\text{CH}_2\text{OH}$ (ethanol), $\text{CH}_3\text{CH}_2\text{CH}_2\text{OH}$ (propanol), $\text{CH}_3\text{CH}_2\text{CH}_2\text{CH}_2\text{OH}$ (butanol), etc. constitute a homologous group, i.e., OH(hydroxyl). Since they have the same functional group, i.e., OH (hydroxyl). Since they have the same functional group, they show similar chemical properties. The difference between any two successive members is a CH_2 group or 14 mass units. Their physical properties such as melting point and boiling point increase as the molecular mass increases. Their solubility in water, however, decreases with increase in molecular mass.

Q.20 How can ethanol and ethanoic acid be differentiated on the basis of their physical and chemical properties ?

Ans. Distinction base on physical properties :

- (i) Smell : Ethanol has a characteristic smell known as alcoholic smell which is pleasant. Ethanoic acid has vinegar like smell.
- (ii) Boiling points : Boiling point of ethanol (351 K) is less than that of ethanoic acid (391 K).
- (iii) Litmus test : Ethanol is neutral in nature and does not bring any change in the colour of litmus whether blue or red. Ethanoic acid is acidic and changes the colour of a blue litmus strip to red when dipped in it.

Distinction based on chemical properties :

- (i) Action with sodium hydrogencarbonate : On adding a small amount of sodium hydrogencarbonate to ethanoic acid, carbon dioxide gas is evolved with brisk effervescence. However, no such reaction is noticed in case of ethanol.

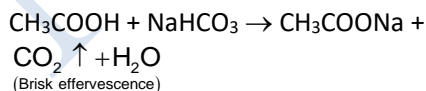

- (ii) Action with caustic alkalies : Ethanoic acid reacts with both sodium hydroxide (NaOH) and potassium hydroxide (KOH) to form corresponding salt and water. Ethanol fails to react with either of these.

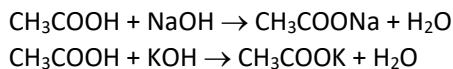

Q.21 Why does micelle formation take place when soap is added to water ? Will a micelle be formed in other solvents such as ethanol also ?

Ans. Soap may be represented by the formula RCOO^-Na^+ where R is an alkyl group which represents long chain of carbon with fifteen or more atoms. Oil drops containing dirt particles and water do not mix. Soap helps in their mixing by reducing interfacial tension or friction. Actually it forms a sort of bridge between oil drops and water in which the alkyl portion (hydrophobic end) point towards oil drop while other portion COO^-Na^+ (hydrophilic end) is directed towards water. This is known as micelle formation. Thus, soap helps in the formation of a stable emulsion between oil and water. Ethanol and other similar solvents which are of organic nature do not help in micelle formation because soap is soluble in them.

Q.22 Why are carbon and its compounds used as fuels for most applications ?

Ans. Carbon burns in oxygen or air to form carbon dioxide gas. The reaction is highly exothermic. That is why different forms of coal are used as fuels. The most important compounds of carbon are hydrocarbons. Just like carbon, hydrogen also readily burns in oxygen or air to form water producing heat. The hydrocarbon methane (CH_4) is a constituent of natural gas. Propane (C_3H_8) and butane (C_4H_{10}) are present in liquid petroleum gas (L.P.G.). Petrol and kerosene also contain different hydrocarbons. Therefore, these are used as fuels.

Q.23 Explain the formation of scum when hard water is treated with soap.

Ans. Soap is basically sodium or potassium salt of higher fatty acid. Hard water contains in it Ca^{2+} and Mg^{2+} ions as their salts. When soap is added to hard water, the corresponding calcium and magnesium salts are formed. There are in the form of precipitates, also called 'scum'.

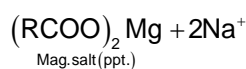
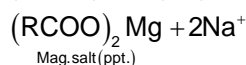

CHEMISTRY

Q.24 What change will you observe if you test soap with litmus paper (blue or red) ?

Ans. When soap is dissolved in water, the solution is alkaline in nature due to the formation of alkali NaOH or KOH. The solution changes the colour of red litmus to blue. However, the solution does not change the colour of blue litmus.

Q.25 What is hydrogenation ? What is its industrial application ?

Ans. Addition of hydrogen to an unsaturated carbon compound is called hydrogenation reaction. In industry, hydrogenation reaction is used for preparing vegetable ghee from vegetable oils. Vegetable oils such as groundnut oil, cottonseed oil, which contain double bonds in their molecules, are converted into ghee by hydrogenation in the presence of Ni. The process of converting a vegetable oil into a solid fat (vegetable ghee) is called hydrogenation of oil.

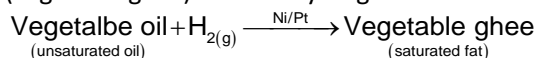

Q.26 Which of the following hydrocarbons undergo addition reactions : C₂H₆, C₃H₈, C₃H₆, C₂H₂ and CH₄ ?

Ans. In order that a hydrocarbon may undergo addition reaction, it must be unsaturated in nature. It must be either an alkene (C = C) with general formula C_nH_{2n} or an alkyne (C ≡ C) with general formula C_nH_{2n-2}. Out of the list of the hydrocarbons given :

- C₃H₆ (Propene) is an alkene with C = C bond. It corresponds to general formula C_nH_{2n} (n = 3).
- C₂H₂ (Ethyne) is an alkyne with C ≡ C bond. It corresponds to general formula C_nH_{2n-2} (n = 2).

Both these hydrocarbons take part in addition reaction. For example, they react with hydrogen upon heating to 473 K in the presence of nickel catalyst to form corresponding alkanes.

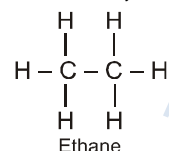
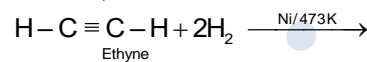
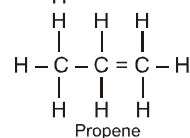
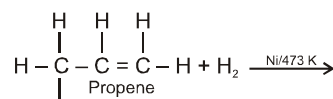

Q.27 Give a test that can be used to differentiate chemically between butter and cooking oil ?

Ans. Butter is saturated in nature while cooking oil is unsaturated. This means that cooking oil has at least one C = C bond present in the constituting compounds while butter does not have any such bond. The distinction between them can be made by reacting with bromine water or bromine dissolved in carbon tetrachloride. Cooking oil will discharge the yellow colour of bromine while butter will not.

Q.28 Explain the mechanism of cleansing action of soaps.

Ans. When an oily (dirty) piece of cloth is put into soap solution, the hydrocarbon part of the soap molecule attaches itself to the oily drop, and the -COO⁻ end orients itself towards water. The Na⁺ ions in solution arrange themselves around the -COO⁻ ions. The negatively charged micelle so formed entrap the oily dirt. The negatively charged micelles repel each other due to the electrostatic repulsion. As a result, the tiny oily dirt particles do not come together and get washed away in water during rinsing.

KNOWLEDGE BASKET

MULTIPLE CHOICE QUESTIONS

- Q.1** The number of 4° carbon atoms in 2,2,4,4-tetramethylpentane is -
(1) 1 (2) 2 (3) 3 (4) 4
- Q.2** Which is a general formula of alkenes -
(1) C_nH_{2n+2} (2) C_nH_{2n}
(3) C_nH_{2n-2} (4) None of the above
- Q.3** The functional group represent alcohol is -
(1) - OH (2) - CHO
(3) - COOH (4) $>C=O$
- Q.4** Which of the following is the purest form of carbon-
(1) charcoal (2) coal
(3) diamond (4) graphite
- Q.5** Organic compounds will always contain -
(1) carbon (2) hydrogen
(3) nitrogen (4) sulphur
- Q.6** Methane, ethane and propane are said to form a homologous series because all are -
(1) hydrocarbons
(2) saturated compounds
(3) aliphatic compounds
(4) differ from each other by a CH_2 group
- Q.7** When methane is burnt in an excess of air, the products of combustion are -
(1) C and H_2O (2) CO and H_2O
(3) CO_2 and H_2 (4) CO_2 and H_2O
- Q.8** Which of the following gases is called 'marsh gas'-
(1) H_2 (2) CH_4 (3) C_2H_4 (4) C_2H_2
- Q.9** The final product of chlorination of methane in the sun light is -
(1) CH_3Cl (2) CH_2Cl_2 (3) $CHCl_3$ (4) CCl_4
- Q.10** When ethane is burnt in excess of air, the products of combustion are -
(1) C and H_2O (2) CO and H_2O
(3) CO_2 and H_2 (4) CO_2 and H_2O
- Q.11** The number of oxygen molecules used in the combustion of 1 molecule of ethanol is -
(1) 1 (2) 2 (3) 3 (4) 4
- Q.12** General formula of alkyne is -
(1) C_nH_{2n+2} (2) C_nH_{2n} (3) C_nH_{2n-2} (4) C_nH_n
- Q.13** When vanaspati oil reacts with hydrogen then it convert into vanaspati ghee. In this process catalyst used is :
(1) Fe (2) Mo (3) V (4) Ni
- Q.14** Observe the following pairs of organic compounds:
(I) C_4H_9OH and C_5H_{11OH}
(II) C_7H_{15OH} and C_5H_{11OH}
(III) C_6H_{13OH} and C_3H_7OH
Which of these pair is a homologous series according to increasing order of carbon atom.
(1) (III) only (2) (II) only
(3) (I) only (4) All of these
- Q.15** Carbon exists in the atmosphere in the form of
(1) carbon monoxide only
(2) carbon monoxide in traces and carbondioxide
(3) carbon dioxide only
(4) coal
- Q.16** Buckminster fullerence in an allotropic form of
(1) phosphorus (2) sulphur
(3) carbon (4) tin
- Q.17** Oils on treating with hydrogen in the presence of palladium or nickel catalyst form fats. This is an example of
(1) addition reaction
(2) substitution reaction
(3) displacement reaction
(4) oxidation reaction
- Q.18** Chlorine reacts with saturated hydrocarbons at room temperature in the
(1) absence of sunlight
(2) presence of sunlight
(3) presence of water
(4) presence of hydrochloric acid

CHEMISTRY

- Q.19** Pentane has the molecular formula C_5H_{12} . It has
- (1) 5 covalent bonds
 - (2) 12 covalent bonds
 - (3) 16 covalent bonds
 - (4) 17 covalent bonds

- Q.20** Structural formula of benzene is

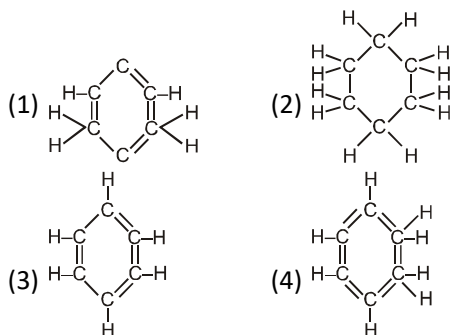

- Q.21** Carbon forms four covalent bonds by sharing its four valence electrons with four univalent atoms, e.g. hydrogen. After the formation of four bonds, carbon attains the electronic configuration of
- (1) helium
 - (2) neon
 - (3) argon
 - (4) krypton

- Q.22** Which of the following does not belong to the same homologous series ?

(1) CH_4 (2) C_2H_6 (3) C_3H_8 (4) C_4H_8

- Q.23** The enzyme involved in the oxidation of ethanol to form vinegar is -

(1) zymase (2) oxidase
 (3) acetobacter (4) invertase

- Q.24** Glacial acetic acid is -

(1) 100 % acetic acid free of water
 (2) solidified acetic acid
 (3) gaseous acetic acid
 (4) frozen acetic acid

- Q.25** When ethanoic acid is heated with $NaHCO_3$ the gas evolved is -

(1) H_2 (2) CO_2 (3) CH_4 (4) CO

- Q.26** During decarboxylation of ethanoic acid with sodalime ($NaOH + CaO$), CO_2 is removed as -

(1) CO_2 (2) CO (3) Na_2CO_3 (4) $CaCO_3$

- Q.27** When ethanoic acid reacts with ethanol a sweet smelling product is formed. The functional group in the product is -

(1) aldehyde (2) ketone
 (3) alcohol (4) ester

- Q.28** Detergents can lather well in -

(1) soft water
 (2) hard water
 (3) river water
 (4) any one of the above

- Q.29** 'Drinking alcohol' is very harmful and it ruins the health. 'Drinking alcohol' stands for -

(1) drinking methyl alcohol
 (2) drinking ethyl alcohol
 (3) drinking propyl alcohol
 (4) drinking isopropyl alcohol

- Q.30** The treatment of acetic acid with lithium aluminium hydride produces -

(1) methanol (2) ethanol
 (3) ethanal (4) methanol

- Q.31** The fermentation reactions are carried out in temperature range of -

(1) $20-30^\circ C$ (2) $30-40^\circ C$
 (3) $40-50^\circ C$ (4) $50-60^\circ C$

- Q.32** Soaps are sodium salts of fatty acids. Which of the following fatty acids does not form soap -

(1) butyric acid
 (2) oleic acid
 (3) palmitic acid
 (4) stearic acid

- Q.33** The OH group of an alcohol or the $-COOH$ group of a carboxylic acid can be replaced by -Cl using:

(1) phosphorus pentachloride
 (2) hypochlorous acid
 (3) chlorine
 (4) hydrochloric acid

- Q.34** Which compound represent the vinegar circa -

(1) $HCOOH$
 (2) CH_3CHO
 (3) $HCHO$
 (4) CH_3COOH

- Q.35** A & B both compounds give H_2 gas with sodium. If A & B react in presence of acid catalyst then they form ethyl acetate. Thus, A & B would be-

(1) CH_3COOH , CH_3OH
 (2) $HCOOH$, CH_3COOH
 (3) CH_3COOH , C_2H_5OH
 (4) C_3H_7COOH , C_3H_7OH

- Q.36** During the cleansing action of soap dirt is surrounded by soap molecules as in the given figure.

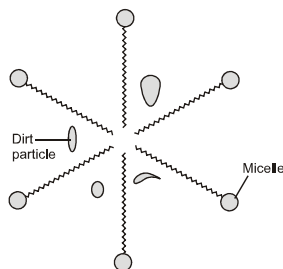

Soap molecule is like a tadpole which has a head and tail. These head and tail respectively are :

- (1) hydrophobic and hydrophilic
(2) hydrophobic and hydrophobic
(3) hydrophilic and hydrophilic
(4) hydrophilic and hydrophobic
- Q.37** A phenomenon by which an element occurs in different physical modification in same physical state is called
- (1) isomerism (2) allotropy
(3) amorphous (4) crystalline
- Q.38** Number of free electron(s) in each carbon atom in graphite is/are
- (1) two (2) four (3) one (4) three
- Q.39** In fullerence carbon atoms are arranged in mixed
- (1) tetragons and pentagons
(2) pentagons and hexagons
(3) pentagones and heptagons
(4) all are correct
- Q.40** Carbon forms a large number of organic compounds due to
- (1) catenation
(2) tendency to form multiple bonds
(3) isomerism
(4) all of these
- Q.41** Diamond is not good conductor of electricity because
- (1) it is very hard
(2) its structure is very compact
(3) it is not water soluble
(4) it has no free electrons

- Q.42** The difference in molecular weight of two consecutive members of a homologous series is
- (1) 15 (2) 14 (3) 8 (4) 9
- Q.43** The general formula of an ester where R represents alkyl group is
- (1) ROH (2) RCOOH (3) RCOOR (4) RH
- Q.44** The functional group present in butanone is
- (1) carboxyl (2) ketonic
(3) aldehydic (4) alcoholic
- Q.45** The IUPAC name of CH_3CHO is
- (1) acetaldehyde (2) methanal
(3) ethanal (4) formaldehyde
- Q.46** The functional group of aldehyde is
- (1) $-\text{CHO}$ (2) $-\overset{\text{O}}{\parallel}{\text{C}}-$
(3) $-\text{COOH}$ (4) $-\text{COOR}$
- Q.47** All the members of homologous series of alkynes have the general formula
- (1) C_nH_{2n} (2) $\text{C}_n\text{H}_{2n+2}$
(3) $\text{C}_n\text{H}_{2n-2}$ (4) $\text{C}_n\text{H}_{2n-4}$
- Q.48** Alcohols can be prepared by hydration of
- (1) alkenes (2) alkanes
(3) alkynes (4) acids
- Q.49** The reaction $\text{CH}_4 + \text{Cl}_2 \xrightarrow[\text{light}]{h\nu} \text{CH}_3\text{Cl} + \text{HCl}$ is an example of
- (1) addition reaction
(2) substitution reaction
(3) elimination reaction
(4) oxidation reaction
- Q.50** When ethanoic acid is heated with NaHCO_3 the gas evolved is
- (1) H_2 (2) CO_2 (3) CH_4 (4) CO
- Q.51** Methane, ethane and propane are said to form a homologous series because all are
- (1) hydrocarbons
(2) saturated hydrocarbons
(3) aliphatic hydrocarbons
(4) differ from each other by $-\text{CH}_2$ group
- Q.52** The reaction,
 $2\text{C}_2\text{H}_5\text{OH} + 2\text{Na} \rightarrow 2\text{C}_2\text{H}_5\text{ONa} + \text{H}_2$
suggest that ethanol is
- (1) acidic in nature (2) basic in nature
(3) amphoteric (4) neutral

CHEMISTRY

Q.53 Ethene can be prepared by reaction of ethanol with

- (1) hot conc. H_2SO_4 (2) alkaline KMnO_4
(3) sodium metal (4) NaHCO_3

Q.54 Which compound gives effervescence with sodium metal but not with sodium bicarbonate ?

- (1) Ethanol (2) Ethanoic acid
(3) Ethanal (4) Ester

Q.55 The structural formula of ethyl ethanoate is

- (1) $\text{CH}_3 - \overset{\text{O}}{\parallel} \text{C} - \text{OCH}_3$
(2) $\text{CH}_3 - \overset{\text{O}}{\parallel} \text{C} - \text{OCH}_2\text{CH}_3$
(3) $\text{CH}_3\text{CH}_2 - \overset{\text{O}}{\parallel} \text{C} - \text{OCH}_2\text{CH}_3$
(4) $\text{CH}_3\text{CH}_2 - \overset{\text{O}}{\parallel} \text{C} - \text{OCH}_3$

Q.56 Conversion of ethanol to ethanoic acid is a/an

- (1) substitution reaction
(2) oxidation reaction
(3) addition reaction
(4) rearrangement reaction

Q.57 In the reaction, $\text{CH}_3\text{COONa} + \text{NaOH} \rightarrow$ the gas obtained is

- (1) C_2H_6 (2) C_2H_2 (3) CH_4 (4) C_3H_8

Q.58 Ethanol on complete oxidation gives

- (1) carbon dioxide and water
(2) acetaldehyde
(3) acetic acid
(4) acetone

Q.59 When the stopper of a bottle containing a colourless liquid was removed, it gave out smell like that of vinegar. The liquid in the bottle could be

- (1) hydrochloric acid
(2) sodium hydroxide solution
(3) acetic acid solution
(4) sodium carbonate solution

Q.60 C_2H_4 reacts with hydrogen in presence of Ni to give

- (1) CH_4 (2) C_2H_6 (3) HCOOH (4) HCHO

Q.61 The substance that would not at all be formed during the reaction of methane and chlorine in presence of sunlight is

- (1) CH_3Cl (2) CHCl_3
(3) $\text{CH}_3\text{CH}_2\text{CH}_3$ (4) CH_2Cl_2

Q.62 Vegetable oil which are liquid at room temperature, can be converted to solid ghee by the process of

- (1) dehydrogenation (2) hydrogenation
(3) halogenation (4) dehydration

Q.63 The following reaction is an example of

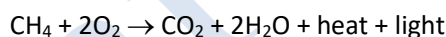

- (1) addition reaction
(2) substitution reaction
(3) combustion reaction
(4) displacement reaction

Q.64 Complete the following reaction :

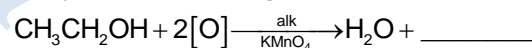

- (1) CH_3COOH (2) HCOOH
(3) CH_3COCH_3 (4) CH_3OH

Q.65 IUPAC name of the compound -

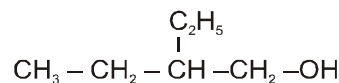

- (1) 2-ethylbutan-1-ol (2) 2-methylpentan-1-ol
(3) 2-ethylpentan-1-ol (4) 3-ethylbutan-1-ol

Q.66 IUPAC name of the compound

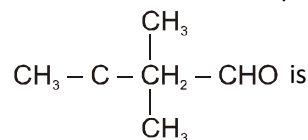

- (1) 3,3,3-Trimethylpropanal
(2) 2,2 - dimethylbutanal
(3) 3,3 - dimethylbutanal
(4) 1,1 - dimethylbutanal

Q.67 Which of the following does not contain a double bond ?

- (1) CO_2 (2) C_2H_4 (3) HCl (4) O_2

Q.68 Number of electrons shared between carbon-carbon atoms in ethene is
(1) 2 (2) 4 (3) 6 (4) 8

Q.69 How many unshared pairs of electrons are present in water molecule ?
(1) One (2) Zero (3) Two (4) Three

Q.70 Which of the following have a triple bond ?
(1) C₂H₄ (2) C₃H₄ (3) C₃H₈ (4) C₃H₉

Q.71 The number of isomers of pentane is
(1) 2 (2) 3 (3) 4 (4) 5

Q.72 The general formula of cycloalkanes is
(1) C_nH_{2n+2} (2) C_nH_{2n-2}
(3) C_nH_{2n-1} (4) C_nH_{2n}

Q.73 Which of the following belong to the same homologous series ?
(1) Ethane, ethene, ethyne
(2) Propanol, propanone, propanal
(3) Methanol, ethanol, propanol
(4) Ethane, ethanol, ethanoic acid

Q.74 Unsaturation in the organic compound can be tested by the help of
(1) Baeyer's test
(2) Fehling's test
(3) chlorination reaction
(4) dehydration reaction

Q.75 The IUPAC name of $\text{CH}_3 - \text{CH}_2 - \underset{\text{CH}_3}{\text{CH}} - \overset{\text{CH}_3}{\underset{\text{CH}_3}{\text{C}}} - \text{CH}_3$ is
(1) 2,2,3-trimethylpentane
(2) 3,4,4-trimethylpentane
(3) 2-ethyl-3,3-dimethylbutane
(4) 2,3-dimethylhexane

Q.76 The IUPAC name of the compound CH₂ = C(CH₃)₂ is
(1) 1,1-dimethylprop-2-ene
(2) 2-methylprop-1-ene
(3) 2-ethyl-3,3-dimethylbutane
(4) 2,3-dimethylhexane

Q.77 Among the following the one having longest chain is
(1) neo-pentane (2) iso-pentane
(3) 2-methylpentane (4) 2, 2-dimethylbutane

Q.78 The IUPAC name of the compound
 $\text{CH}_3 - \underset{\text{CH}(\text{CH}_3)_2}{\text{CH}} - \text{CH}_3$ is

- (1) 2-isopropylpropane
(2) iso-butane
(3) 2,3-dimethylbutane
(4) 2,3-dimethylpentane

Q.79 An organic compound X with molecular formula C₂H₄O₂ turns blue litmus red and gives brisk effervescence with sodium bicarbonate. Identify the compound.

- (1) Methanoic acid
(2) Ethanoic acid
(3) Propanoic acid
(4) Butanoic acid

Q.80 In C₆H₁₄ the number of possible isomers is
(1) 3 (2) 6 (3) 4 (4) 5

Q.81 Which of the following set of compounds have same molecular formula ?

- (1) Butane and iso-butane
(2) Cyclohexane and hexene
(3) Propanal and propanone
(4) All of these

Q.82 Which of the following is an isomeric pair ?

- (1) Ethane and propane
(2) Ethane and ethene
(3) Propane and butane
(4) Butane and 2-methylpropane

Q.83 Which of the following hydrocarbons does not decolourise bromine water ?

- (1) C₁₀H₂₂
(2) C₆H₁₂
(3) C₁₀H₁₈
(4) C₁₀H₂₀

Q.84 What is observed when acetic acid and sodium bicarbonate solution are mixed ?

- (1) A colourless odourless gas is liberated
(2) A colourless gas that turns blue litmus red
(3) A colourless gas which burns with a pop sound
(4) Both (1) and (2)

CHEMISTRY

Q.85 2 mL of ethanoic acid was taken in each of the three test tubes A, B and C. To these test tubes 2 mL, 4 mL and 8 mL of water was added respectively. Which test tube will give a clear solution ?

- (1) Test tube A only
- (2) Test tube B only
- (3) Test tube A and B only
- (4) All the test tubes

FILL IN THE BLANKS

Q.86 Carbon has electrons in its valence shell.

Q.87 Ethanol reacts with sodium metal to produce gas.

Q.88 The general formula for alkynes is

Q.89 The next higher homologue of heptane is

Q.90 The compounds C_3H_6 and C_4H_8 belong to homologous series of

Q.91 In water molecule there are unshared pairs of electrons.

Q.92 The number of C – H bonds in ethane is

Q.93 The formula of ethanoic acid is

Q.94 The functional group present in ethyl ethanoate is

Q.95 The compound having an IUPAC name propane has a structural formula

TRUE OR FALSE

Q.96 Properties of carbon compounds depend on the functional groups present in them.

Q.97 The hydrolysis of an ester in presence of an alkali is known as saponification.

Q.98 Covalent bonds are formed by transfer of electrons between two atoms.

Q.99 In saturated as well as unsaturated compounds carbon is tetravalent.

Q.100 Both aldehydes and ketones contain same functional group called carbonyl group ()

Q.101 Alkenes decolourise bromine water but alkynes do not.

Q.102 The reaction of ethanol with conc. H_2SO_4 gives ethane.

Q.103 Carboxylic acids react with alcohols to form esters.

Q.104 When ethanoic acid is treated with $NaHCO_3$, hydrogen gas is evolved.

Q.105 Ethanol is oxidised by alkaline $KMnO_4$ to oxalic acid.

CONCEPTUAL

VERY SHORT ANSWER TYPE QUESTIONS

- Q.1** How is the conductivity shown by carbon compounds ?
- Q.2** Why does carbon not form the ionic compounds?
- Q.3** What happens when a small piece of sodium is dropped into ethanol ?
- Q.4** How does the conductivity vary in diamond and graphite ?
- Q.5** What are saturated and unsaturated compounds? Give example also.
- Q.6** What is the role of a functional group in an organic compound?
- Q.7** What is the common name of simplest acid and why ?
- Q.8** An organic compound 'X' with molecular formula C_2H_6O , on oxidation with acidified potassium dichromate gives ethanoic acid. What is the compound X ? Write equation also.
- Q.9** Which two of the following compounds belong to same homologous series ?
 $C_2H_6O_2$, C_2H_6O , C_2H_6 , CH_4O
- Q.10** What is the valency of carbon in its compounds?
- Q.11** Out of ketonic and aldehydic groups, which is the terminal functional group ?
- Q.12** The formula of a hydrocarbon is C_nH_{2n} . Name the family to which it belongs and also predict its nature.
- Q.13** An unknown compound has the smell of vinegar. Identify it.
- Q.14** What do we get when ethanoic acid reacts with ethanol in the presence of concentrated sulphuric acid ?
- Q.15** Vapours of a hydrocarbon were passed through bromine dissolved in carbon tetrachloride. The yellow colour of bromine get discharged ? Predict the nature of the hydrocarbon.

SHORT ANSWER TYPE QUESTIONS

- Q.16** (a) Why are covalent compounds generally poor conductors of electricity ?

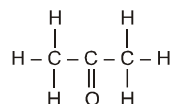

- (b) Name the following compound :
- (c) Name the gas evolved when ethanoic acid is added to sodium carbonate. How would you prove the presence of this gas ?
- Q.17** Give reasons for the following observations :
- (a) The element carbon forms a very large number of compounds.
- (b) Air holes of a gas burner have to be adjusted when the heated vessels get blackened by the flame.
- (c) Use of synthetic detergents causes pollution of water.
- Q.18** Name the type of reaction by which bromoethane can be converted to ethanol. Write reaction also.
- Q.19** (a) What is a 'homologous series' of substance?
- (b) In an organic compound, which parts largely determine its physical and chemical properties?
- (c) Write a chemical equation to represent the reaction of ethanol with acidified solution of potassium dichromate.
- Q.20** An organic compound A having molecular formula $C_2H_4O_2$ reacts with sodium metal and evolves a gas B which readily catches fire. A also reacts with ethanol in the presence of concentrated sulphuric acid to form sweet smelling substance C used in making perfumes.
- (a) Identify the compounds A, B and C.
- (b) Write balanced chemical equations to represent to conversion of :
- (i) compound A into compound B
- (ii) compound A into compound C.

CHEMISTRY

Q.21 An organic compound 'X' which is sometimes used as an antifreeze has the molecular formula C_2H_6O . 'X' on oxidation gives a compound 'Y' which gives effervescence with baking soda solution. What can 'X' and 'Y' be ?

Write the structural formulae.

Q.22 What are the reactive sites for addition reactions in unsaturated hydrocarbons ? Give an example.

Q.23 Three hydrocarbons A, B and C have melting points $-183^\circ C$, $-138^\circ C$, and $-95.3^\circ C$ respectively. Which one has minimum number of carbon atoms in molecule ?

Q.24 What is meant by saponification ? Give an example.

Q.25 What is esterification? Or What happens when ethyl alcohol and acetic acid react with each other in the presence of conc. H_2SO_4 ?

Q.26 What is hydrogenation ? What is its industrial application ?

Q.27 What are the advantages of synthetic detergents over soaps?

Q.28 How will you distinguish between ethanol and ethanoic acid ?

Q.29 What is meant by (i) decarboxylation and (ii) esterification of acetic acid ?

Q.30 Two carbon compounds A and B have the molecular formula C_3H_8 and C_3H_6 respectively. Which one of the two is most likely to show addition reaction ? Justify your answer. Explain with the help of a chemical equation, how an addition reaction is useful in vegetable ghee industry?

LONG ANSWER TYPE QUESTIONS

Q.31 Explain the formation of oxygen molecule.

Q.32 What are the main properties of covalent compounds with respect to melting and boiling points, solubility and conductivity ?

Q.33 How will you show formation of ethylene molecule with the help of Lewis dot structure ?

Q.34 Write the main characteristics of a homologous series.

Q.35 Write the structural formulae for

(i) 2-methyl-2-butene

(ii) 2-methylpropene

Q.36 Write IUPAC names of the following compounds:

(i) CH_3CH_2COOH

(ii) CH_3CHO

(iii) $\begin{array}{c} CH_3CHCH_3 \\ | \\ CH(CH_3)_2 \end{array}$

(iv) $CH_3CH_2CH_2OH$

(v) $\begin{array}{c} CH_3CHCH_3 \\ | \\ OH \end{array}$

Q.37 A hydrocarbon has three carbon atoms. Write down its molecular formulae as

(i) alkane

(ii) alkene

(iii) alkyne

(iv) alcohol derivative

(v) aldehyde derivative

(vi) ketone derivative

(vii) acid derivative

Q.38 What is the difference between combustion and oxidation ? Under what conditions an oxidation reaction becomes combustion?

Q.39 What is scum ? How is it formed ?

Q.40 What happens when ethanoic acid reacts with

(i) magnesium

(ii) sodium carbonate

(iii) Sodium hydroxide

Write chemical equation in each case.

ACTIVITY BASED QUESTIONS

- Q.1** A four carbon atoms containing neutral organic compound X reacts with sodium metal to evolve a gas which burns with a 'pop' sound. Another four carbon atoms containing carbon compound reacts with sodium hydrogencarbonate to evolve a gas which turns lime water milky. When compounds X and Y are heated together in the presence of a little of concentrated sulphuric acid, then a new compound Z is formed.
- Q.2** An organic compound A (molecular formula $C_2H_4O_2$) reacts with Na metal to form a compound B and evolves a gas which burns with a pop sound. Compound A on treatment with an alcohol C in the presence of a little of concentrated sulphuric acid forms a sweet-smelling compound D (molecular formula $C_3H_6O_2$). Compound D on treatment with NaOH solution gives back B and C. Identify A, B, C and D.
- Q.3** A neutral organic compound X of molecular formula C_2H_6O on oxidation with acidified potassium dichromate gives an acidic compound Y. Compound X reacts with Y warming in the presence of conc. H_2SO_4 to give a sweet smelling substance Z. What are X, Y and Z ?
- Q.4** An organic compound having the molecular formula C_3H_6O can exist in the form of two isomers A and B having different functional groups. The isomer A is a liquid which is used as a solvent for nail polish. The isomer B is also a liquid. An aqueous solution of one of the lower homologues of B is used for preserving biological specimens in the laboratory
- What is compound A ?
 - Write the electron-dot structure of A.
 - What is compound B ?
 - Write the electron-dot structure of B.
 - Name the lower homologue of compound B which is used in preserving biological specimens.
- Q.5** A colourless organic liquid X of molecular formula $C_2H_4O_2$ turns blue litmus to red. Another colourless organic liquid Y of molecular formula C_3H_6O has no action on any litmus but it is used as a nail polish remover. A yet another colourless organic liquid Z of molecular formula C_2H_6O has also no action on litmus but it is used in tincture of iodine.
- Name the liquid X. To which homologous series does it belong ? Give the name of another member of this homologous series.
 - Name the liquid Y. To which homologous series does it belong ? Write the name of another member of this homologous series.
 - Can you name an organic compound having the same molecular formula as liquid Y but which belongs to a different homologous series ? What is this homologous series ?
 - Name the liquid Z. To which homologous series does it belong ? Write the name of another member of this homologous series.
- Q.6** You are given an organic compound having the molecular formula C_3H_8 . Give the name and formula of the compound formed :
- when one H atom of C_3H_8 is replaced by a C_1 atom.
 - when one H atom of C_3H_8 is replaced by OH group.
 - when one H atom of C_3H_8 is replaced by a CHO group.
 - when one H atom of C_3H_8 is replaced by COOH group.
 - when two H atoms joined to the middle carbon atom of C_3H_8 are replaced by one O atom.
- Q.7** Two organic compounds A and B have the same molecular formula C_6H_{12} . Write the names and structural formulae :
- If A is a cyclic compound
 - If B is an open chain compound
 - Which compound contains single bonds as well as a double bond ?
 - Which compound contains only single bonds?

CHEMISTRY

- Q.8** An element E exists in three allotropic forms A, B and C. In allotrope A, the atoms of element E are joined to form spherical molecules. In allotrope B, each atom of element E is surrounded by three other E atoms to form a sheet like structure. In allotrope C, each atom of element E is surrounded by four other E atoms to form a rigid structure.
- Name the element E.
 - What is allotrope A ?
 - What is allotrope B ?
 - What is allotrope C ?
 - Which allotrope is used in making jewellery?
 - Which allotrope is used in making anode of a dry cell ?
- Q.9** A solid element X has four electrons in the outermost shell of its atom. An allotrope Y of this element is used as a dry lubricant in machinery and also in making pencil leads.
- What is element X ?
 - Name the allotrope Y.
 - State whether allotrope Y is a good conductor or non-conductor of electricity.
 - Name one use of allotrope Y (other than lubrication and pencil leads)
 - Name two other allotropes of element X.
- Q.10** The solid element A exhibits the property of catenation. It is also present in the form of a gas B in the air which is utilised by plants in photosynthesis. An allotrope C of this element is used in glass cutters.
- What is element A ?
 - What is the gas B ?
 - Name the allotrope C.
 - State another use of allotrope C (other than in glass cutters).
 - Name another allotrope of element A which exists as spherical molecules.
 - Name a yet another allotrope of element A which exists as spherical molecule

PRACTICE QUESTIONS BASED ON IUPAC NOMENCLATURE

IUPAC NOMENCLATURE

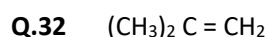
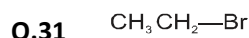
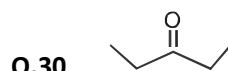
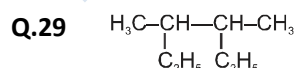
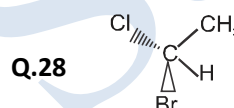
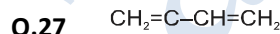
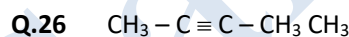
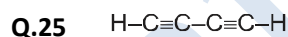
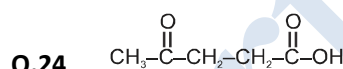
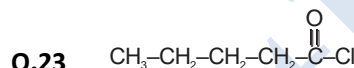
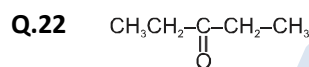
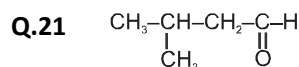
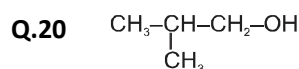
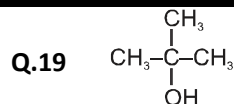
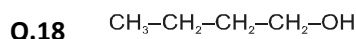
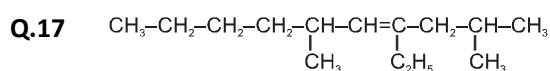
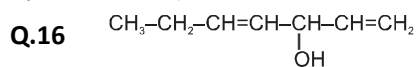
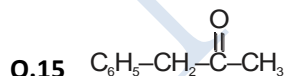
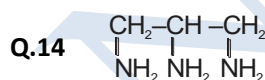
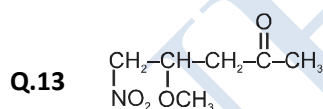
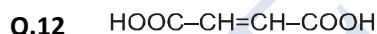
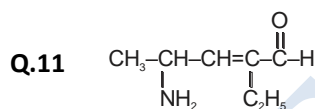
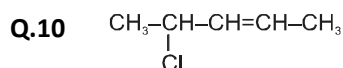
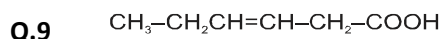
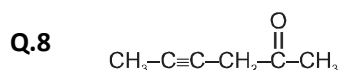
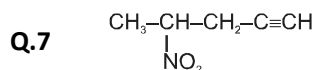
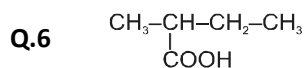
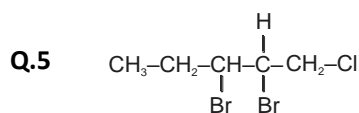
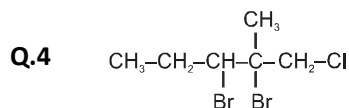
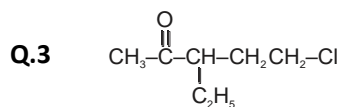
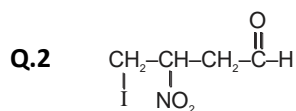
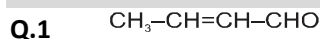

Q.33 Predict which name is wrong :

- (1) 3 - Ethyl - 4, 4 - dimethyl heptane
- (2) 4,4 - dimethyl - 3 - ethyl heptane
- (3) 5 - Ethyl - 4, 4 - dimethyl heptane
- (4) 4,4 - Bis (Methyl) - 3 - ethyl heptane

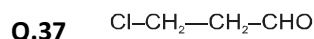
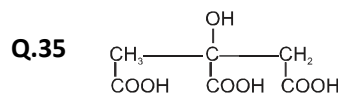
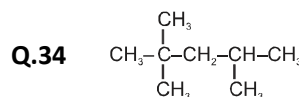

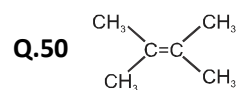
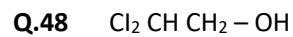
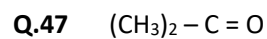
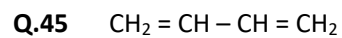
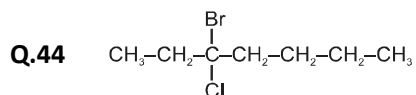
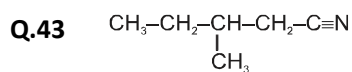
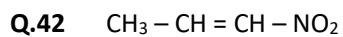
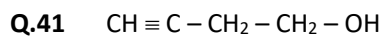
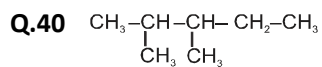
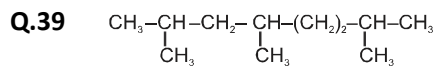
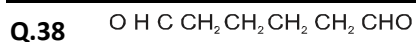
CHEMISTRY

OLYMPIAD BASED EXERCISE

Q.1 Why shouldn't we light a candle in a closed room with people ?

- (1) The CO₂ formed causes breathlessness.
- (2) Carbon particles are formed which are dangerous for respiratory tract.
- (3) Methane gas, which is poisonous, is formed.
- (4) Carbon monoxide gas which reduces the ability of blood to carry oxygen is formed.

Q.2 Why do black shoe polishes have an oily feel ?

- (1) Shoe polish is a mixture of oil and powdered graphite.
- (2) On exposure to air, these undergo chemical changes and produce oily substances.
- (3) Vapour of some amount of oil is left over after its preparation.
- (4) These are formed by dissolving charcoal in oil.

Q.3 Graphite cannot be used as a lubricant in space because

- (1) absence of external pressure transforms crystalline graphite to amorphous form
- (2) there is no atmosphere in space, and hence, graphite sublimates in space.
- (3) there is no atmosphere in space, and hence, there is no adsorbed air and water between layers of graphite
- (4) none of the above

Q.4 The existence of an element in different allotropic forms is due to the-

- (1) different arrangement of atoms
- (2) different amounts of energy associated in the formation of each allotrope
- (3) different methods of formation
- (4) all of the above

Q.5 The use of diamond as a gem is due to its

- (1) extreme hardness
- (2) poor conductance
- (3) low density
- (4) high-refractive index

Q.6 Water gas is mixture of

- (1) CO₂ and H₂
- (2) H₂ and CH₄
- (3) CO and H₂
- (4) CO and N₂

Q.7 Graphite fibres are used to reinforce plastic as they

- (1) have weak carbon bonds
- (2) have high - tensile strength
- (3) are brittle
- (4) have weak forces of attraction between layers

Q.8 The IUPAC name of

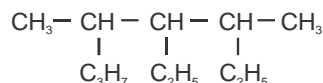

- (1) 3,4 -dimethyl -4-ethyl Octane
- (2) 4 - ethyl -3, 5 -dimethyl Octane
- (3) 2, 3 -dimethyl -4- Propyl Pentane
- (4) 3, 4 -dimethyl -2- Propyl pentane

Q.9 Which among the following pairs belong to the same homologous series ?

- (1) C₃H₄, C₅H₁₀
- (2) C₂H₆, C₄H₁₀
- (3) C₂H₄, C₄H₈
- (4) C₄H₈, C₅H₁₀

Q.10 Which among the following isomers of hexane has the highest boiling point ?

- (1) CH₃-CH₂-CH₂-CH₂-CH₂-CH₃
- (2) $\begin{array}{ccccccc} \text{CH}_3 & - & \text{CH} & - & \text{CH}_2 & - & \text{CH}_2 & - & \text{CH}_3 \\ & & | & & & & & & \\ & & \text{CH}_3 & & & & & & \end{array}$

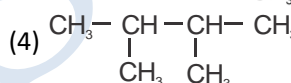
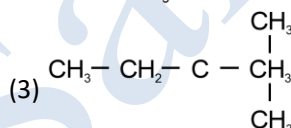

Q.11 The straight chain isomer of C₄H₁₀ is the major component in _____.

- (1) biogas
- (2) petroleum gas
- (3) natural gas
- (4) coal gas

Q.12 The IUPAC name of the following compound is _____.

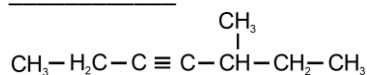

- (1) 2 - ethyl -3- hexyne
- (2) 3-methyl - 4- heptyne
- (3) 5-methyl -3- heptyne
- (4) 5- ethyle - 3 - hexyne

Q.13 Structural formula of 3,4 -dimethyl heptane is

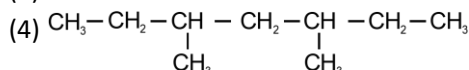
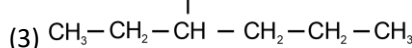
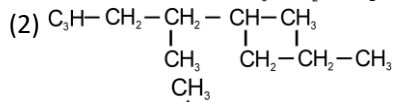
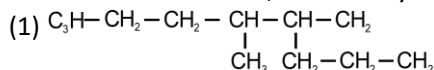

CHEMISTRY

Q.14 The primary suffix for a compound with general formula C_nH_{2n-2} is
(1) -ane (2) -yne (3) -ene (4) -enol

Q.15 A compound on hydrogenation yields ethane by consuming 2 molecules of hydrogen. The same compound on being treated with excess of bromine water gives

- (1) CH_2Br_2 (2) $C_2H_4Br_2$
(3) $C_2H_2Br_4$ (4) C_2H_5Br

Q.16 The reagent used for decarboxylation reaction is

- (1) $NaOH + Ca(OH)_2$ (2) only $NaOH$
(3) $NaOH + CaO$ (4) $NaOH + CaCO_3$

Q.17 1 mole of ethyne on complete combustion gives

- (1) 2 moles of carbon monoxide and half-mole of water
(2) 4 moles of carbon dioxide and 1 mole of water
(3) 2 moles of carbon dioxide and 1 mole of water
(4) 2 moles of carbon dioxide and 2 moles of water

Q.18 Which of the following is an identification test for unsaturation in an organic compound ?

- (1) addition of hydrogen
(2) addition of ozone
(3) addition of bromine
(4) addition of oxygen

Q.19 The hydrocarbon used for welding purpose is

- (1) ethane (2) ethyne
(3) ethene (4) benzene

Q.20 The reagent $NaOH + CaO$ is used for

- (1) carboxylation (2) dehydrogenation
(3) hydrogenation (4) decarboxylation

Q.21 Which of the following structure does not correspond to the chain isomer of pentane ?

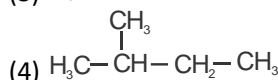
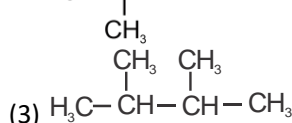
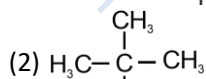
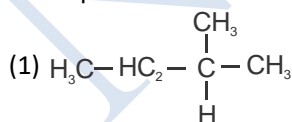

Q.22 The secondary suffix, 'one' indicates the following functional group in the given compounds.



Q.23 Tollen's reagent contains

- (1) silver nitrate
(2) copper nitrate
(3) copper sulphate
(4) ammonical silver nitrate

Q.24 In deodorant soap, the additive added in deodorant is

- (1) glycerol
(2) stearic acid
(3) potassium bicarbonate
(4) 3, 4, 5 - Tribromosalicylaldehyde

Q.25 Four oils, A, B, C and D have the following values of melting points :

- (a) 258 K (b) 273 K
(c) 295 (d) 303 K

Among these, which oil is prohibited from consumption by cardiac patients ?

- (1) a (2) b
(3) c (4) d

Q.26 Catalytic hydrogenation of ethene produces ____.

- (1) ethane (2) acetylene
(3) methane (4) ethyne

Q.27 What is the correct structural formula of 3-Methyl-1-Pentyne ?

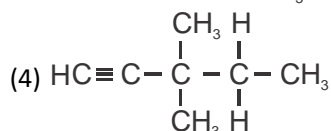
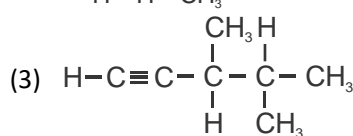
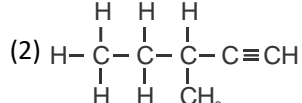
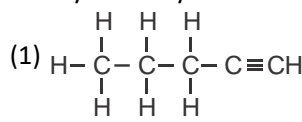

Q.28 Which of the following compounds cannot exhibit chain isomerism ?

- (1) propane (2) butane
(3) pentane (4) hexane

Q.29 Preceding and succeeding homologues of $C_{10}H_{22}$ respectively are

- (1) C_9H_{20} , $C_{11}H_{22}$ (2) C_9H_{20} , $C_{11}H_{24}$
(3) $C_{11}H_{24}$, C_9H_{20} (4) C_8H_{18} , C_9H_{20}

Q.30 Which of the hydrocarbons cannot decolourise the red-coloured solution of bromine in CCl_4 ?

- (1) CH_4 (2) C_2H_4 (3) C_2H_2 (4) C_3H_6

Q.31 Complete hydrogenation of ethyne gives _____

- (1) ethane (2) ethane
(3) methane (4) none of these

Q.32 Assertion (A) : Unsaturated hydrocarbons decolourise the red coloured bromine water.

Reason (R) : Unsaturated hydrocarbon undergoes substitution reaction with bromine water.

- (1) Both A and R. are correct and R is the correct explanation of A.
(2) Both A and R are correct but R is not the correct explanation of A.
(3) A is correct and R is wrong.
(4) A is wrong and R is correct.

Q.33 If third member of alcohol family (homologous series) undergoes esterification reaction with second member of carboxylic acid family then the name of ester formed and its formula will be respectively

- (1) Ethyl propanoate, $CH_3CH_2COOCH_2CH_3$
(2) Propyl ethanoate, $CH_3COOCH_2CH_2CH_3$
(3) Ethyl butanoate, $CH_3CH_2CH_2COOCH_2CH_3$
(4) Ethyl ethanoate, $CH_3COOCH_2CH_3$

Q.34 C_2H_5OH on oxidation with acidified $K_2Cr_2O_7$ gives CH_3COOH . Which of the following statements is/are correct regarding these two compounds ?

- I. They both react with sodium metal to evolve a combustible gas.
II. They both react with $NaHCO_3$ to evolve a gas which turns lime water milky.
III. They both turn blue litmus red.
(1) I and II only (2) II only
(3) I only (4) I, II and III

PREVIOUS YEAR QUESTIONS

Q.1 Detergents Are Salts of - [Raj. Ntse Stage-I/07]

- (1) strong acid and strong base
- (2) strong acid and weak base
- (3) weak acid and strong base
- (4) weak acid and weak base

Q.2 In the Presence of Concentrated Sulphuric Acid, Acetic Acid Reacts With Alcohol To Produce –

[Delhi. Ntse Stage-I/13]

- (1) aldehyde
- (2) alcohol
- (3) ester
- (4) carboxylic acid

Q.3 Fullerece, An Allotrope of Carbon Contains -

[Haryana Ntse Stage-I/13]

- (1) 30 six membered rings
- (2) 24 five membered rings and 10 six membered rings.
- (3) 12 five membered rings and 20 six membered rings
- (4) 18 five membered rings and 15 six membered rings.

Q.4 What Is Iupac Name Of The Following Compound ?

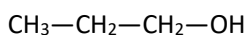

[Maharashtra Ntse Stage-I/13]

- (1) propan-1-ol
- (2) propan-2-ol
- (3) ethan-1-ol
- (4) ethan-2-ol

Q.5 The action of cleaning of oily dirt by soap is based on [Rajasthan Ntse Stage-I/14]

- (1) solubility in water
- (2) hydrophilic property
- (3) hydrophobic property
- (4) presence of both hydrophilic and hydrophobic groups

Q.6 Which Of The Following Is Represented By General Formula $\text{C}_n\text{H}_{2n+2}\text{O}$?

[Haryana_Ntse Stage-I/14]

- (1) Alcohols Only
- (2) Both Alcohols and Ethers
- (3) Aldehydes Only
- (4) Both Aldehydes And Ketones

Q.7 Which of the following series represent only unsaturated hydrocarbons ?

[Karnataka_Ntse Stage-I/14]

- (1) C_2H_6 , C_3H_8 , C_4H_{10}
- (2) C_2H_6 , C_3H_6 , C_4H_{10}
- (3) C_2H_4 , C_3H_6 , C_4H_6
- (4) C_2H_4 , C_3H_8 , C_4H_6

Q.8 Which of the following formulae represents cycloalkanes ? [Maharashtra_Ntse Stage-I/15]

- (1) C_6H_{12}
- (2) C_4H_{10}
- (3) C_6H_6
- (4) C_5H_{14} SW

Q.9 Which of the following is not a straight chain hydrocarbon ? [Maharashtra_ntse stage-i/15]

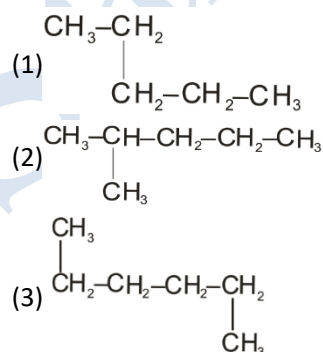

- (4) $\text{CH}_3-\text{CH}_2-\text{CH}_2-\text{CH}_2-\text{CH}_3$

Q.10 1 mole of a hydrocarbon 'X' undergoes complete saturation with 1 mole of hydrogen in presence of a heated catalyst. what would be the formula of 'X' ?

[West Bengal_Ntse Stage-I/15]

- (1) C_2H_6
- (2) C_2H_2
- (3) C_5H_{10}
- (4) C_7H_{16}

Q.11 Which of the following are isomers ?

[West Bengal_Ntse Stage-I/15]

- (1) Butane and Isobutene
- (2) Ethane and Ethene
- (3) Propane and Propyne
- (4) Butane and Isobutane

Q.12 Which of the following has shortest carbon-carbon bond length ? [Delhi_Ntse Stage-I/15]

- (1) C_2H_2
- (2) C_2H_4
- (3) C_2H_6
- (4) C_6H_6

Q.13 Which of the following may be isomer of aldehyde having general formula $C_NH_{2N}O$?

[Delhi_Ntse Stage-I/15]

- (1) Alcohol (2) Ether
(3) Ester (4) Ketone

Q.14 IUPAC name of the first member of homologous series of ketones is

[Rajasthan_Ntse Stage-I/15]

- (1) Ethanone (2) Propanol
(3) Methanone (4) Propanone

Q.15 An alkyne has 4 numbers of hydrogen atoms. what will be the number of carbon atoms in it ?

[Rajasthan_Ntse Stage-I/15]

- (1) Two (2) Three (3) Four (4) Five

Q.16 In Saponification Process, The Fatty Acid Present In The Oils Is Neutralised By Adding

[Karnataka Ntse Stage-1/ 2015]

- (1) Sodium Hydroxide
(2) Aluminium Hydroxide
(3) Calcium Hydroxide
(4) Magnesium Hydroxide

Q.17 Acetic Acid, With The Molecular Formula CH_3COOH Has

[West Bengal Ntse Stage-1/ 2015]

- (1) 8 Covalent Bonds
(2) 7 Covalent Bonds
(3) 9 Covalent Bonds
(4) 10 Covalent Bonds.

Q.18 Ethanol Is Made Unfit For Drinking By Adding

[Raj. Ntsestage-1/2016]

- (1) Propanol (2) Methanal
(3) Methanol (4) Ethanal

Q.19 Identify X In The Following Reaction –

[Raj. Ntsestage-1/2016]

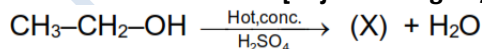

- (1) Ethane (2) Methane
(3) Ethene (4) Ethanol

Q.20 A hydrocarbon having one double bond has 100 carbon atoms in its molecule. the number of hydrogen atoms in its molecule will be:

[Chattisgarh Ntsestage-1/2017]

- (1) 196 (2) 198 (3) 200 (4) 202

Q.21 Write IUPAC Name of:

[Madhya Pradesh Ntsestage-1/2017]

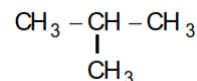

- (1) 2,2-Dimethyl Propane
(2) 2-Methyl Butane
(3) 2,2-Dimethyl Ethane
(4) 2-Methyl Propane

Q.22 The IUPAC name of $\begin{array}{c} CH_3 \\ \diagdown \\ C=CH_2 \\ \diagup \\ CH_3 \end{array}$ is

- (1) 1,1-Dimethyl-2-Ethene
(2) 2-Methyl-1-Propene
(3) 2,2-Dimethyl Ethene
(4) 2-Methyl Prop-2-Ene

Q.23 The First Organic Compound Which Was Synthesized In The Laboratory Was

[Bihar Ntsestage-1/2018]

- (1) Methane
(2) Urea
(3) Acetic Acid
(4) Cane Sugar

Q.24 (a) If The Assertion As Well As Reason Are Correct And The Reason Is The Correct Explanation Of The Assertion.

(b) If The Assertion As Well As The Reason Are Correct, But Reason Is Not The Correct Explanation Of The Assertion

(c) If The Assertion Is Correct But Reason Is Not

(d) If The Reason Is Correct But Assertion Is Not

Assertion : Graphite Is Chemically More Reactive Than Diamond.

Reason : Diamond Is Very Hard But Graphite Is Soft.

Choose The Correct Answer :

[Bihar Ntsestage-1/2018]

- (1) (a) (2) (b) (3) (d) (4) (a)

Q.25 IUPAC name of isopentane is :

[Raj. Ntsestage-1/2018]

- (1) 2-Ethyl Propane
(2) Pentane
(3) 2-Methyl Butane
(4) 2,2-Dimethyl Propane

CHEMISTRY

Q.26 The Number Of Coordinate Covalent Bonds In The Structure Of Nitric Acid Is :

[Raj. Ntsestage-1/2019]

- (1) 0 (2) 1 (3) 2 (4) 3

Q.27 The Compounds Which Contains Both ionic and Covalent Bonds Is :

[Chhattisgarh Ntsestage-1/2019]

- (1) CH₄ (2) Cl₂ (3) NaCN (4) KCl

Q.28 IUPAC Name of The Following Compound Will Be:

[Delhi Ntsestage-1/2019]

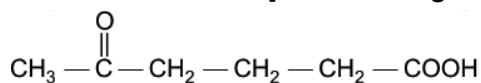

- (1) 2-Keto Hexan-6 oic Acid
(2) 5- Keto Hexanoic Acid
(3) Methyl Ketone Butanoic Acid
(4) 5-Aldo Hexanoic Acid

Q.29 Benzene (C₆H₆) Have:

[Delhi Ntsestage-1/2019]

- (1) 12 Covalent Bonds
(2) 15 Covalent Bonds
(3) 18 Covalent Bonds
(4) 9 Covalent Bonds

Q.30 In The Following Compound Which Two Are Not Isomers To Each Other :

[W. B. Ntsestage-1/2019]

- (1) (CH₃)₂CHCH₃, (CH₃)₂CHCH₂CH₃
(2) CH₃CH₂OH, CH₃-O-CH₃
(3) C₂H₅-O-C₂H₅, CH₃-O-C₃H₇
(4) CH₃CH₂CHO, CH₃COCH₃

Q.31 The Reaction of AgNO₃ With Acetylene Shows Which Type of Property Of Acetylene

[W. B. Ntsestage-1/2019]

- (1) Acidic (2) Oxidizing
(3) Basic (4) Reducing

Q.32 Which reagent will be helpful differentiating ethanoic acid from ethanol ?

[W. B. Ntsestage-1/2019]

- (1) Br₂/CCl₄
(2) Dilute NaOH
(3) Dilute HCL Solution
(4) NaHCO₃

Q.33 Two Organic Compounds 'X And 'Y' React With Sodium Metal And Both Produce Same Gas 'A'. With Sodium Hydrogen Carbonate Only Compound 'Y' Reacts To Produce Gas 'B' Identity X, Y, A And B.

[Haryana Ntsestage-1/2019]

- (1) X =C₂H₄, Y= C₂H₆OH, A=CO₂, B=H₂
(2) X = C₂H₅OH, Y= CH₃COOH, A =H₂, B=CO₂
(3) X = CH₃OH, Y = C₂H₅OH, A =H₂, B =CO₂
(4) X = CH₃COOH, Y = HCOOH, A= CO₂, B =H₂

Q.34

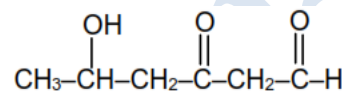

Which Functional Groups Are Present In This Organic Compound?

[Haryana Ntsestage-1/2019]

- (1) Alcohol, Ketone and Ester
(2) Alcohol, Ketone and Carboxylic Acid
(3) Alcohol, Ketone and Aldehyde
(4) Alcohol, Aldehyde and Carboxylic Acid

Q.35 The I.U.P.A.C. Name Of Fosllowing Compound Is.

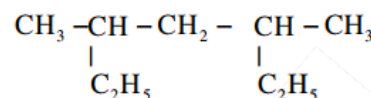

[Haryana Ntsestage-1/2019]

- (1) 2,4,- Diethyl Pantane
(2) 2-Ethyl-4-Methyl Hexane
(3) 3,5 Diemethyl Hexane
(4) 3,5 - Dimethyl Heptane

Q.36 IUPAC name of

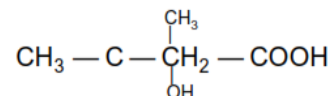

[A.P. Ntsestage-1/2019]

- (1) 2-Hydroxy-2-Methyl Butanoic Acid
(2) 3-Hydroxy-2-Methyl Butane
(3) 3,3-Diethyl Butane
(4) 3-Ethyl-2-Methyl Propane

Q.37 When a vegetative oil is treated with hydrogen in the presence of nickel catalyst it forms fat (vegetable ghee). this is an example of

[Punjab Ntsestage-1/2019]

- (1). Displacement Reaction
(2) Decompostion Reaction
(3). Addition Reaction
(4) Double Displacement Reaction

Q.38 How many isomers are possible for the hydrocarbon with molecular formula C_6H_{14} ?

[Kerala Ntsestage-1/2019]

- (1) 4 (2) 5 (3) 6 (4) 7

Q.39 When propanol is treated with excess hot concentrated sulphuric acid, the resulting product will be : [Kerala Ntsestage-1/2019]

- (1) Ethane (2) Ethane
(3) Propane (4) Propene

Q.40 $C_4H_8O_2$ and C_4H_8O are the molecular formula of the organic compounds of which class ?

[Odisha Ntsestage-1/2019]

- (1) Aldehyde And Ketone
(2) Carboxylic Acid And Ester
(3) Ester And Aldehyde
(4) Esters And Ethers

Q.41 $CH_3CH_2OH \xrightarrow[443K]{Conc. H_2SO_4}$

The products formed in the above reaction is/are [Delhi Ntsestage-1/2020]

- (1) Ethene and H_2O (2) Ethyne and H_2O
(3) Ethane and H_2O (4) Methane and H_2O

Q.42 Denatured alcohol is a mixture of

[Delhi Ntsestage-1/2020]

- (1) CH_3OH and $HCHO$
(2) CH_3OH and CH_3COOH
(3) C_2H_5OH and CH_3OH
(4) C_2H_5OH and CH_3COOH

Q.43 For welding a mixture of oxygen and _____ is burnt [Delhi Ntsestage-1/2020]

- (1) Benzene (2) Butane
(3) Methane (4) Ethyne

Q.44 Which of the following element does not show allotropy? [Delhi Ntsestage-1/2020]

- (1) Phosphorus (2) Sulphur
(3) Oxygen (4) Aluminium

Q.45 which of the following compound do not contain aldehydic group(-CHO) in them? [Haryana Ntsestage-1/2020]

- i. formaldehyde
ii. propanal
iii. butanol
iv. pentane-3-one
v. 3-methyl hexanal

- (1) III & IV (2) IV & V
(3) I & III (4) II & III

Q.46 Vinegar is prepared from

[Haryana Ntsestage-1/2020]

- (1) Ethanoic acid (2) Citric acid
(3) Methanoic acid (4) Butanoic acid

Q.47 Which of the following non-metal is good conductor of electricity ?

[MP.Ntsestage-1/2020]

- (1) Graphite
(2) Phosphorus
(3) Hydrogen
(4) Bromine

HOTS (HIGH ORDER THINKING SKILLS)

Q.1 Write the IUPAC name of the following:

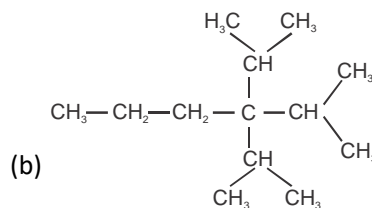
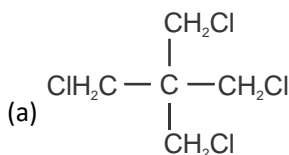

Q.2 Identify the functional groups in the following :-

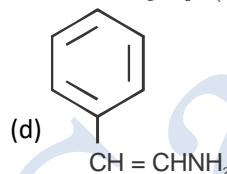
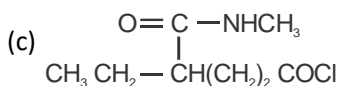
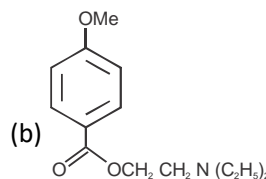
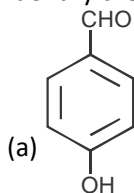

Q.3 Draw structures of all isomeric aldehydes & ketones (carbonyl compounds) having molecular formula $\text{C}_5\text{H}_{10}\text{O}$.

Q.4 An alkane has molecular weight 86. What is the molecular formula of the alkane? Write down all possible isomers for this molecular formula.

Q.5 Are the following names correct in IUPAC system?

- (i) Pent - 3 - yne
- (ii) 4, 4, 3 - Trimethyl - hex - 1 - yne
- (iii) Hexa - 1, 6 - diene.

ANSWER KEY
KNOWLEDGE BASKET

| | | | | | | | | | | | | | | | |
|------|----|----|----|----|----|----|----|----|----|----|----|----|----|----|----|
| Que. | 1 | 2 | 3 | 4 | 5 | 6 | 7 | 8 | 9 | 10 | 11 | 12 | 13 | 14 | 15 |
| Ans. | 2 | 1 | 1 | 3 | 1 | 4 | 4 | 2 | 4 | 4 | 3 | 3 | 4 | 3 | 2 |
| Que. | 16 | 17 | 18 | 19 | 20 | 21 | 22 | 23 | 24 | 25 | 26 | 27 | 28 | 29 | 30 |
| Ans. | 3 | 1 | 2 | 3 | 3 | 2 | 4 | 3 | 1 | 2 | 3 | 4 | 4 | 2 | 2 |
| Que. | 31 | 32 | 33 | 34 | 35 | 36 | 37 | 38 | 39 | 40 | 41 | 42 | 43 | 44 | 45 |
| Ans. | 1 | 1 | 1 | 4 | 3 | 4 | 2 | 3 | 2 | 4 | 4 | 2 | 3 | 2 | 3 |
| Que. | 46 | 47 | 48 | 49 | 50 | 51 | 52 | 53 | 54 | 55 | 56 | 57 | 58 | 59 | 60 |
| Ans. | 1 | 3 | 1 | 2 | 2 | 4 | 1 | 1 | 1 | 2 | 2 | 3 | 3 | 3 | 2 |
| Que. | 61 | 62 | 63 | 64 | 65 | 66 | 67 | 68 | 69 | 70 | 71 | 72 | 73 | 74 | 75 |
| Ans. | 3 | 2 | 3 | 1 | 1 | 3 | 3 | 2 | 3 | 2 | 2 | 4 | 3 | 1 | 1 |
| Que. | 76 | 77 | 78 | 79 | 80 | 81 | 82 | 83 | 84 | 85 | | | | | |
| Ans. | 2 | 3 | 3 | 2 | 4 | 4 | 4 | 1 | 4 | 4 | | | | | |

FILL IN THE BLANKS :
Q. 86 four

Q. 87 hydrogen

Q. 88 C_nH_{2n-2}
Q. 89 octane

Q. 90 alkenes

Q. 91 two

Q. 92 six

Q. 93 CH_3COOH
Q. 94 ester

Q. 95
True or false :
Q. 96 T

Q. 97 T

Q. 98 F

Q. 99 T

Q. 100 T

Q. 101 F

Q. 102 F

Q. 103 T

Q. 104 F

Q. 105 F

OLYMPIAD BASED EXERCISE

| | | | | | | | | | | | | | | | |
|------|----|----|----|----|----|----|----|----|----|----|----|----|----|----|----|
| Que. | 1 | 2 | 3 | 4 | 5 | 6 | 7 | 8 | 9 | 10 | 11 | 12 | 13 | 14 | 15 |
| Ans. | 4 | 3 | 3 | 4 | 4 | 3 | 2 | 2 | 4 | 1 | 2 | 3 | 2 | 2 | 3 |
| Que. | 16 | 17 | 18 | 19 | 20 | 21 | 22 | 23 | 24 | 25 | 26 | 27 | 28 | 29 | 30 |
| Ans. | 3 | 3 | 3 | 2 | 4 | 3 | 3 | 4 | 4 | 4 | 1 | 2 | 1 | 2 | 1 |
| Que. | 31 | 32 | 33 | 34 | 35 | 36 | 37 | 38 | 39 | 40 | | | | | |
| Ans. | 1 | 2 | 4 | 4 | 1 | 3 | 3 | 4 | 2 | 3 | | | | | |

PREVIOUS YEARS QUESTIONS

| | | | | | | | | | | | | | | | |
|------|----|----|----|----|----|----|----|----|----|----|----|----|----|----|----|
| Que. | 1 | 2 | 3 | 4 | 5 | 6 | 7 | 8 | 9 | 10 | 11 | 12 | 13 | 14 | 15 |
| Ans. | 1 | 3 | 3 | 1 | 4 | 2 | 3 | 1 | 2 | 3 | 4 | 1 | 4 | 4 | 2 |
| Que. | 16 | 17 | 18 | 19 | 20 | 21 | 22 | 23 | 24 | 25 | 26 | 27 | 28 | 29 | 30 |
| Ans. | 1 | 1 | 3 | 3 | 3 | 4 | 2 | 2 | 2 | 4 | 2 | 3 | 2 | 2 | 1 |
| Que. | 31 | 32 | 33 | 34 | 35 | 36 | 37 | 38 | 39 | 40 | 41 | 42 | 43 | 44 | 45 |
| Ans. | 1 | 4 | 2 | 3 | 2 | 1 | 3 | 2 | 4 | 3 | 1 | 3 | 4 | 4 | 1 |
| Que. | 46 | 47 | | | | | | | | | | | | | |
| Ans. | 4 | 1 | | | | | | | | | | | | | |

QUOTATION FOR STUDY MATERIAL PACKAGE

| Study Material | No. Of Module | Rate Per Set (Above 50 Student) | Rate Per Set (Above 100 Student) |
|-----------------------------------|-----------------------|---------------------------------|----------------------------------|
| Class 6 th | 6 | 1600/Set | 1400/Set |
| Class 7 th | 7 | 1800/Set | 1600/Set |
| Class 8 th | 6 | 2000/Set | 1800/Set |
| Class 9 th | 8 | 2200/Set | 2000/Set |
| Class 10 th | 9 | 2600/Set | 2400/Set |
| Class 11 th (One Year) | NEET - 13 JEE - 12 | 2800/Set | 2500/Set |
| Class 12 th (One Year) | NEET - 11 JEE - 11 | 2800/Set | 2500/Set |

TEST PAPER DETAILS

Complementary

Chapterwise Tests and Test series for all Classes

Written Solutions

Maths, Physics and Mental Ability

Special Discount for your School for
Online Courses Including Recorded Lectures &
Live Classes on
NEET SARTHI Platform

Saksham Course Class - 9th

Daksh Course Class - 10th

HARD COPY STUDY MATERIAL



PREPARED BY TOP KOTA FACULTIES



RECORDED LECTURES

for Board NCERT & NTSE



Online/offline Test Series

Chapterwise & Full Syllabus Tests

Scan QR Code

DOWNLOAD

NOW

THE NEET SARTHI APP



Contact Product Manager

Mr. Karunesh Choudhary

80009 32030, 7568539900

Head Office : 5 K 3 Parijaat Colony, Mahaveer Nagar IIIrd - 324005, Kota (Raj.)

Branch Office : B-308, Indra Vihar, Kota (Raj.) 324005

Web : www.neetsarthi.com | Email : management.neetsarthi@gmail.com

Student Care No. : **8090908042**